



ALPHABET OF LIGHT

BIG - Bjarke Ingels Group



BJARKE INGELS GROUP

BIG is a group of architects, designers and thinkers operating within the fields of architecture, urbanism, research and development with offices in Copenhagen and New York City. BIG has created a reputation for completing buildings that are as programmatically and technically innovative as they are cost and resourceconscious in the design sector both in Italy and worldwide, and designing various successful appliances for the Group.

BIG + ARTEMIDE

The collaboration between BIG and Artemide stems from the desire to share with the company that is a leading innovator in the lighting field a series of ideas aimed at creating light in response to a vision

“With Alphabet of light we have designed a modular system of straight and bended components of light that enables you to write with letters, be a straight line or a curve.” **BIG**

LINEAR & CIRCULAR

BIG - Bjarke Ingels Group



PATENT PENDING MI102016000025996

PATENT PENDING 102017000037606



Artemide
App
Compatible



Artemide

MIXING CHAMBER

Patent Pending
MI102016000025996

®

Artemide

ELECTRO MECHANICAL CONNECTIONS

Patent Pending 102017000037606

Artemide

3 LINEAR MODULES

120_180_240



Materials: plastic material diffusing body, aluminum heatsink
Colours: heat sink in anodized aluminium, tube in diffusing PMMA

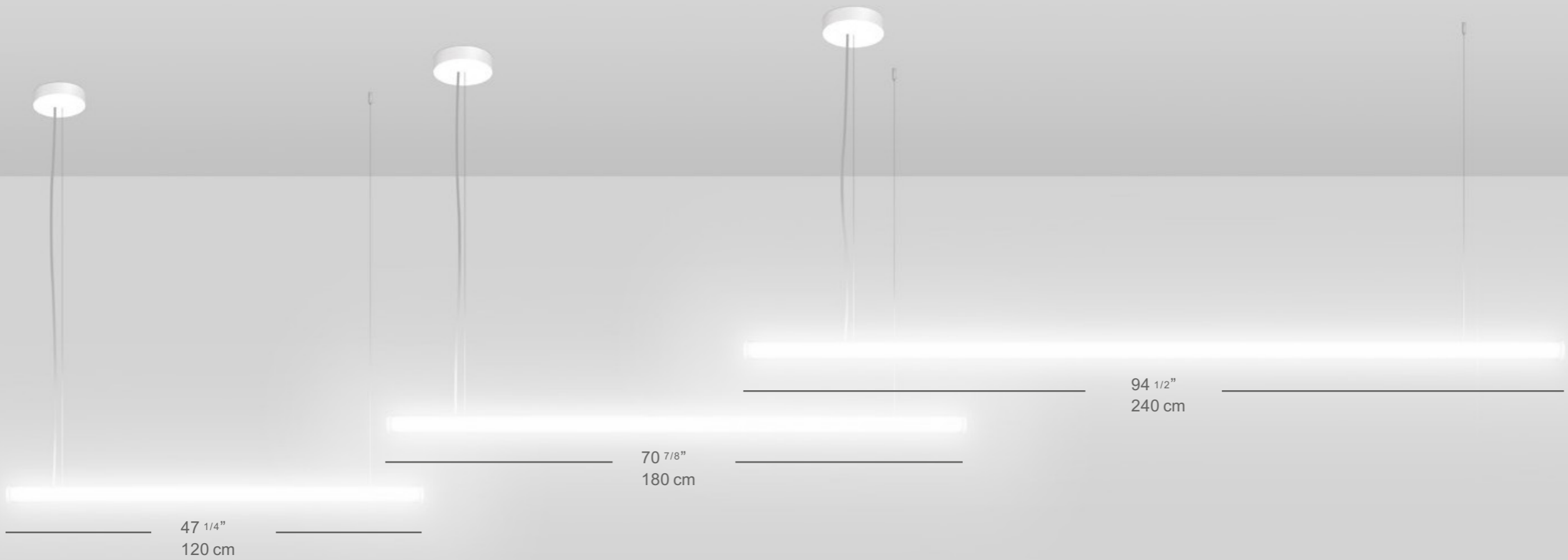

LINEAR 120

3484 lumens
35 watts

LINEAR 180

5226 lumens
50 watts

LINEAR 240

6968 lumens
63 watts



ESPRESSO		COLD COFFEE		SPECIALTIES	
HAYES VALLEY ESPRESSO	\$3.50	BELLA DOMOVAN	\$4.00	AVOCADO TOAST	\$4.50
DECAF ESPRESSO	\$3.50	LIMITED RELEASE	\$4.50	LIÈGE WAFFEL	\$4.50
SINGLE ORIGIN ESPRESSO	\$4.50				
MACCHIATO	\$4.00				
CAPPUCCINO	\$4.50				
CAFFÈ LATTE	\$4.50				
CAFFÈ MOCHA	\$5.50				
ALMOND MILK					

BLUE BOTTLE COFFEE, OAKLAND, CA, USA
Photo: Suzanne Scott Photography

2 CIRCULAR MODULES

90_155



Materials: plastic material diffusing body, aluminum heatsink
Colours: heat sink in anodized aluminum, tube in diffusing PMMA



CIRCULAR 90
6304 lumens
55 watts

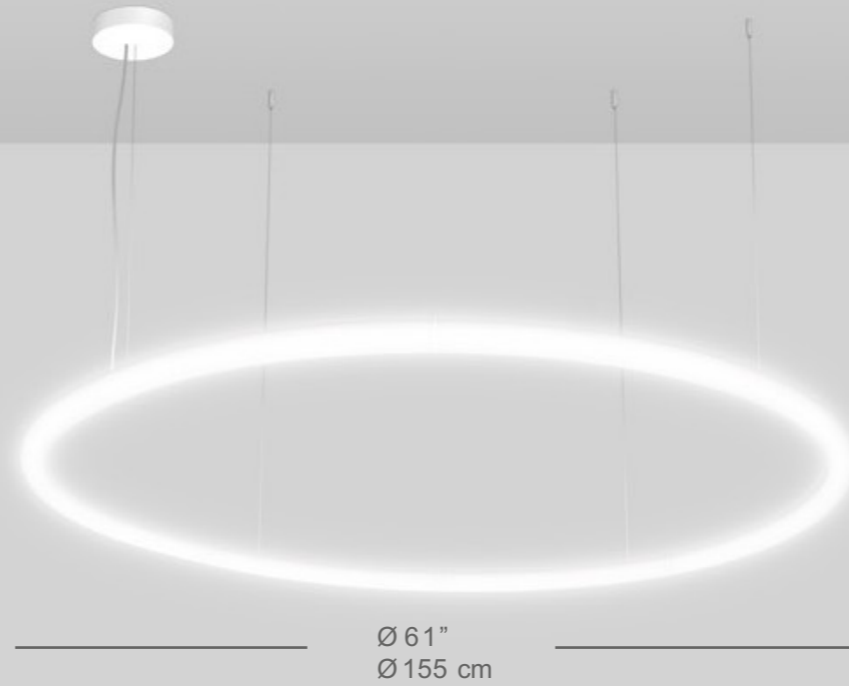

CIRCULAR 155
12667 lumens
110 watts





NUTRIEN WONDERHUB, SASKATOON, CANADA
Project: Titan Marketing Solutions





PENNER DOORS AND HARDWARE OFFICES SASKATOON, CANADA

Project: Titan Marketing Solutions Photo: Stu Kasdorf



ALPHABET OF LIGHT CIRCULAR SUSPENSION

BIG

		Emission	Total Power	Flux
	Alphabet of light Circular Ø155	diffused light	98W	12667lm 3000K /3500K, CRI=80 Dimmable 2 wire / Dimmable 0-10
	Alphabet of light Circular Ø90	diffused light	55W	6304lm 3000K/3500K, CRI=80 Dimmable 2 wire / Dimmable 0-10

ALPHABET OF LIGHT LINEAR SUSPENSION

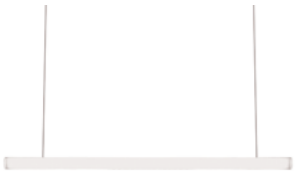
BIG

		Emission	Total Power	Flux
	Alphabet of light Linear 120	diffused light	35W	3484lm 3000K /3500K, CRI=80 Dimmable 2 wire / Dimmable 0-10
	Alphabet of light Linear 180	diffused light	50W	5226lm 3000K /3500K, CRI=80 Dimmable 2 wire / Dimmable 0-10
	Alphabet of light Linear 240	diffused light	63W	6968lm 3000K /3500K, CRI=80 Dimmable 2 wire / Dimmable 0-10



...elmente c'è un'enorme discordanza nei beni che le
...dono, ovvero tra il modo in cui trattano
...il modo di concepire e trattare
...ietà pubblica.'

o la Rovina

In 1973, the same year that Robin Hood Gardens was completed, the Nigerian Public Housing project in St. Louis, Missouri, which had been beset by vandalism since it opened in 1964, was demolished. Architectural historian Charles Jencks declared that its dismantling was the moment 'modern architecture died'. Likewise, in the UK, debates about the impact of estate design on anti-social behaviour both preceded and justified Margaret Thatcher's 'Right to Buy' scheme introduced in 1980, under which by 2014 over 80% of all council housing stock was sold to private owners, without being replaced.

The Road to Ruin

At Robin Hood Gardens, almost as soon as it was occupied, vandalism blighted the communal areas. In 1976 a study found that most tenants interviewed thought the site as a whole was noisy and unattractive, even though they liked their own flats. Tenants' views were also a contained part of the redevelopment consultation process. The council pointed to an official 2008 survey of the residents, 80% of whom apparently favoured demolition, while a self-conducted poll of 143 tenants found 90% favoured refurbishment. The council's case for demolition also cited the increased need for housing and the prohibitive cost of refurbishment, estimated at £77,000 per flat.

The Rain in Reverse





BLUE BOTTLE COFFEE, OAKLAND, CA, USA
Photos: Suzanne Scott Photography.



THE BLONDE SALAD OFFICES, MILAN, ITALY



OFFICES, MADRID, 2018

Artemide

STATEMENT

The Linear and Circular suspension models are available in a variety of sizes.

Their simple geometric shapes can be arranged to help give shape to and enhance the architecture of a space.

Their minimal presence encourages creative arrangement and gives endless design possibilities.





OFFICES, MILANO, ITALY, 2017

Artemide



OFFICES, MILANO, ITALY, 2017



TEATRO ARENA

FICO, BOLOGNA, ITALY, 2017

Artemide

NEW WALL/CEILING VERSION

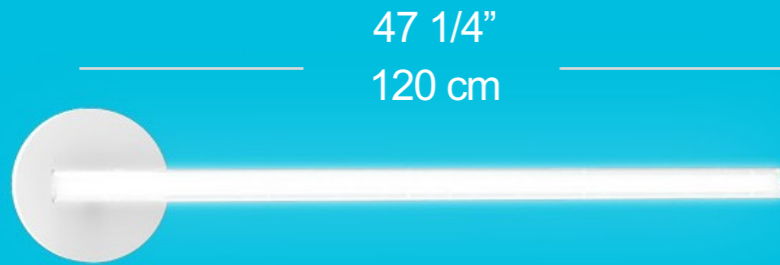

47 1/4"
120 cm

LINEAR 120

3484 lumens
35 watts

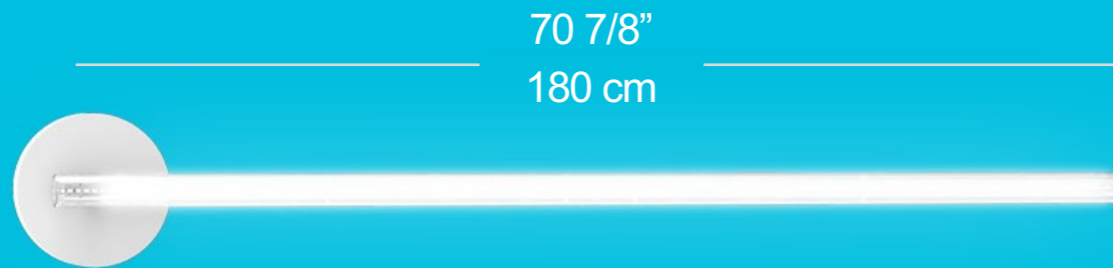

70 7/8"
180 cm

LINEAR 180

5226 lumens
50 watts

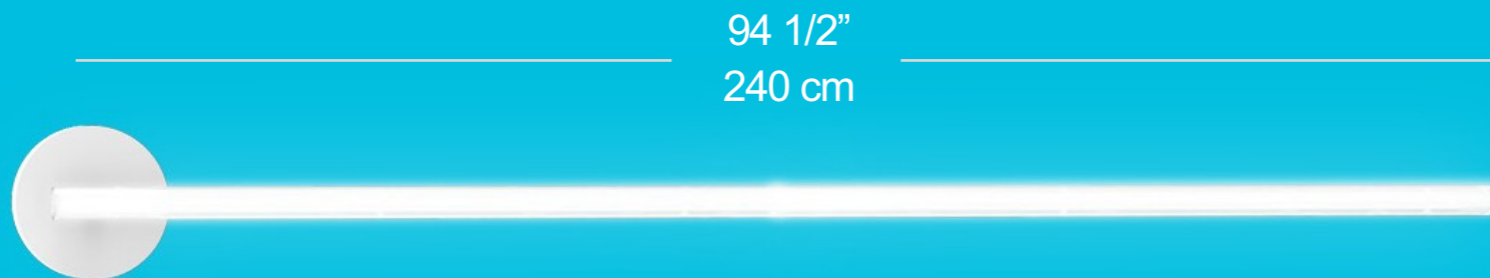

94 1/2"
240 cm

LINEAR 240

6968 lumens
63 watts

Materials: plastic material diffusing body, aluminum heatsink
Colours: heat sink in anodized aluminum, tube in diffusing PMMA

ALPHABET OF LIGHT WALL/CEILING





ALPHABET OF LIGHT LINEAR WALL/CEILING

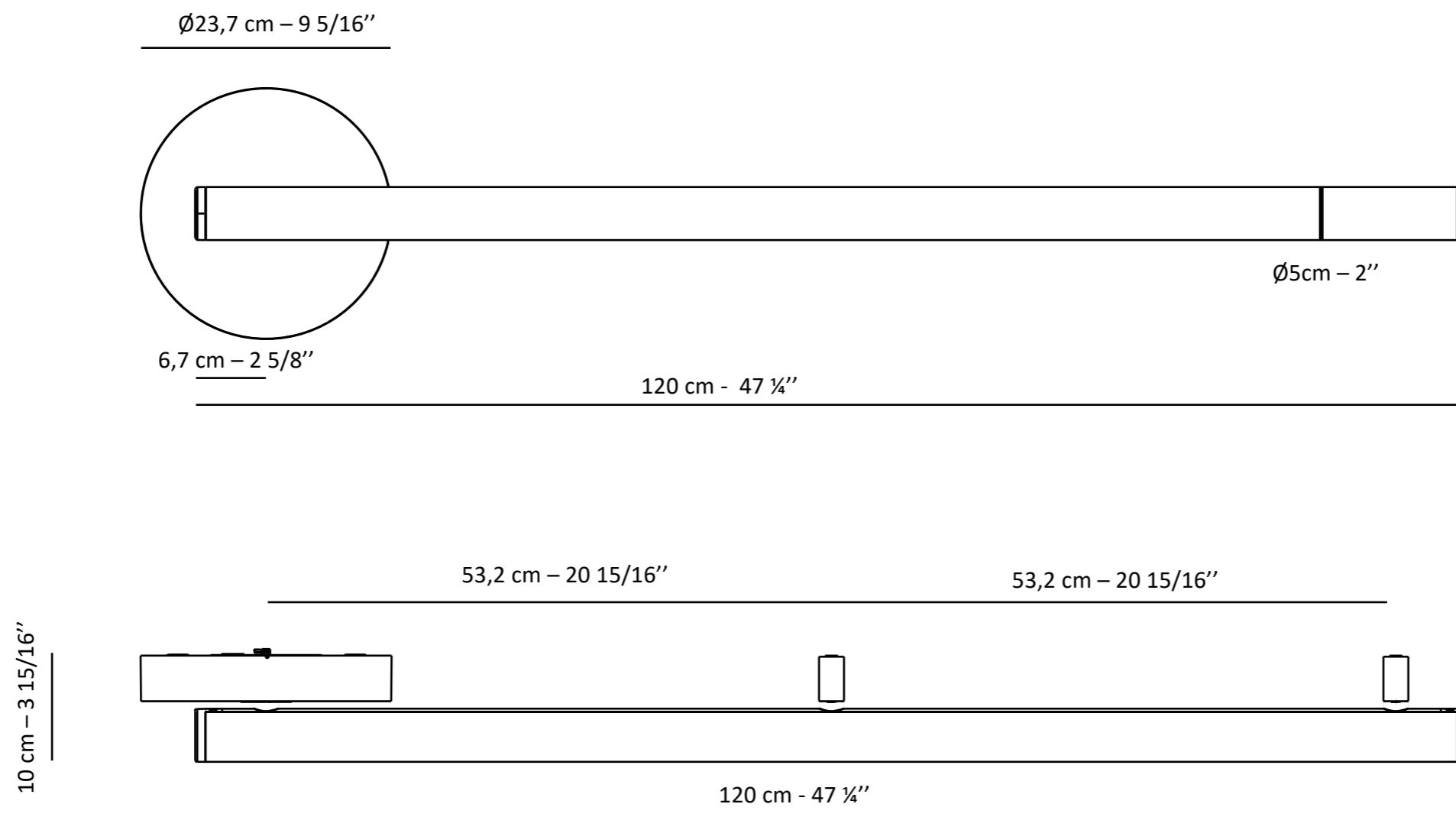

NEW WALL/CEILING VERSION

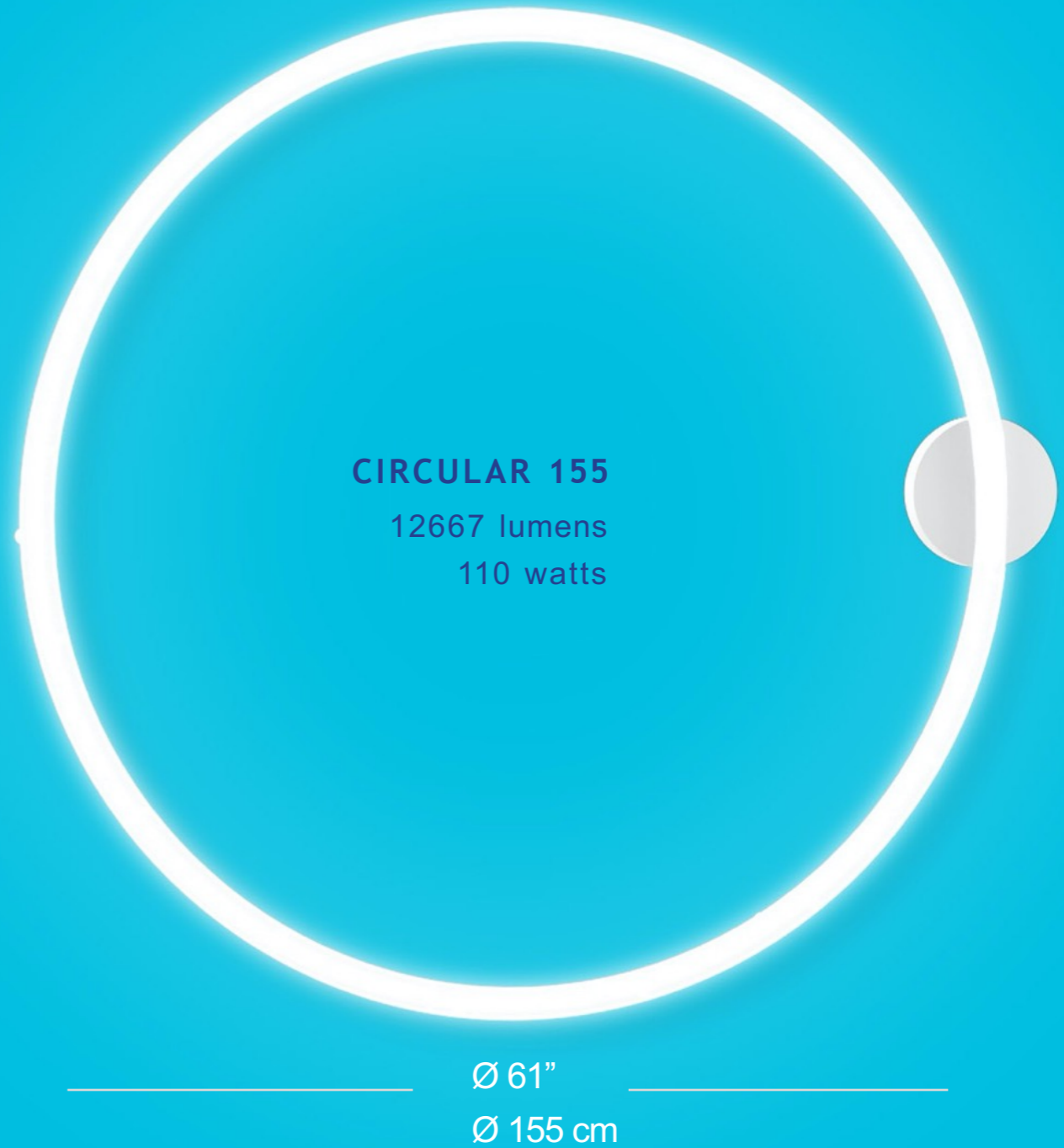

Materials: plastic material diffusing body, aluminum heatsink
Colours: heat sink in anodized aluminum, tube in diffusing PMMA

ALPHABET OF LIGHT WALL/CEILING



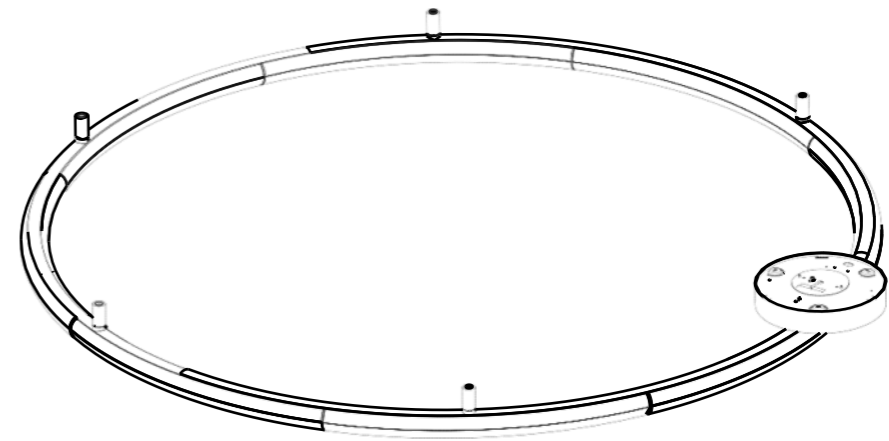
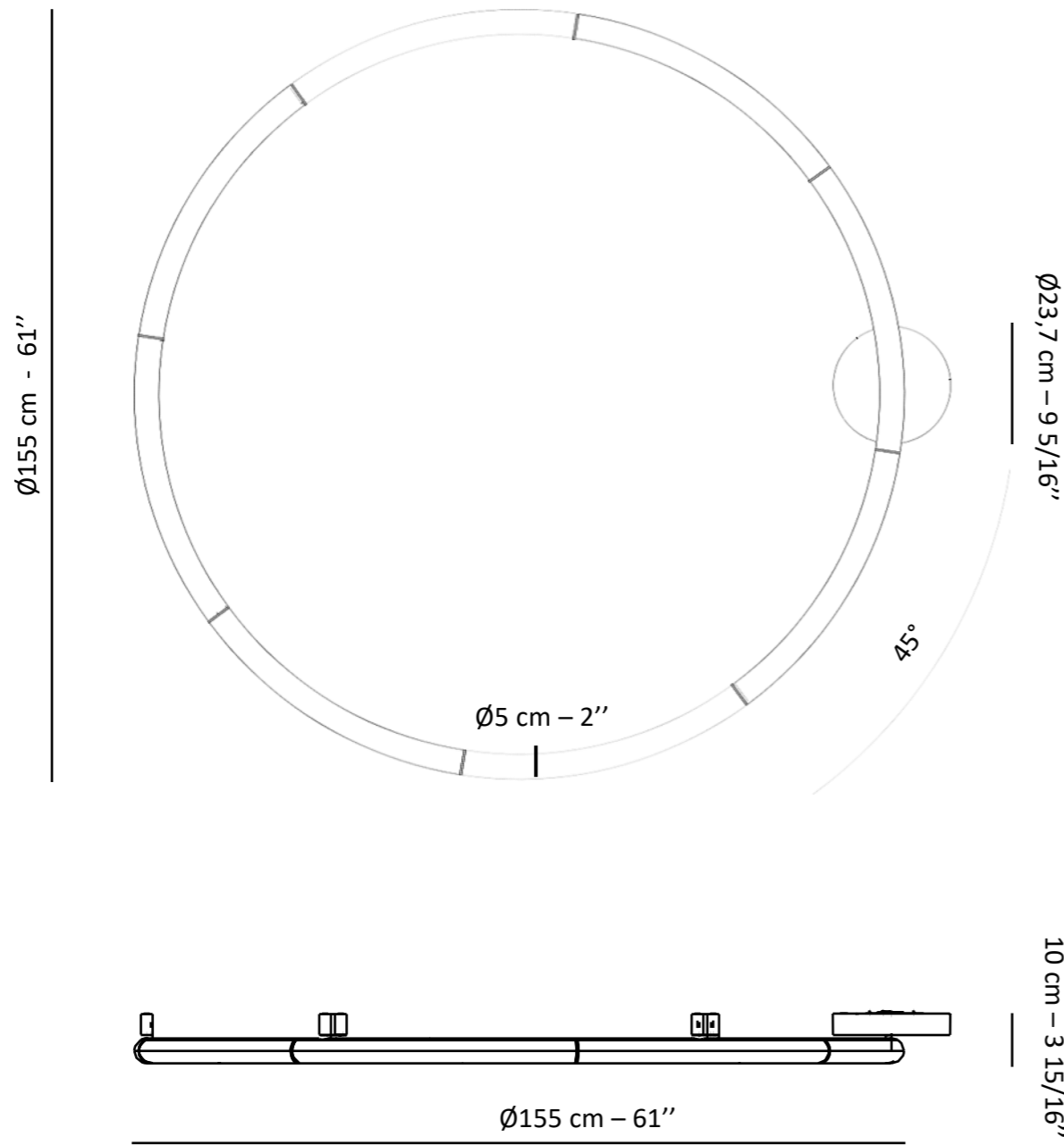

ALPHABET OF LIGHT CIRCULAR WALL/CEILING





ALPHABET OF LIGHT CIRCULAR W/C

BIG

		Emission	Total Power	Flux
	Alphabet of light Circular Ø155	diffused light	110W	12667 lm 3000K /3500K, CRI=80 Dimmable 2 wire / Dimmable 0-10
	Alphabet of light Circular Ø90	diffused light	55W	6304 lm 3000K /3500K, CRI=80 Dimmable 2 wire / Dimmable 0-10

ALPHABET OF LIGHT LINEAR W/C

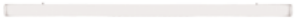
BIG

	Emission	Total Power	Flux
 Alphabet of light Linear 120	diffused light	35W	3484lm 3000K /3500K, CRI=80 Dimmable 2 wire / Dimmable 0-10
 Alphabet of light Linear 180	diffused light	50W	5226lm 3000K /3500K, CRI=80 Dimmable 2 wire / Dimmable 0-10
 Alphabet of light Linear 240	diffused light	68W	6968lm 3000K /3500K, CRI=80 Dimmable 2 wire / Dimmable 0-10

ALPHABET OF LIGHT SYSTEM

BIG - Bjarke Ingels Group

PATENT PENDING MI102016000025996
PATENT PENDING 102017000037606

Artemide[®]

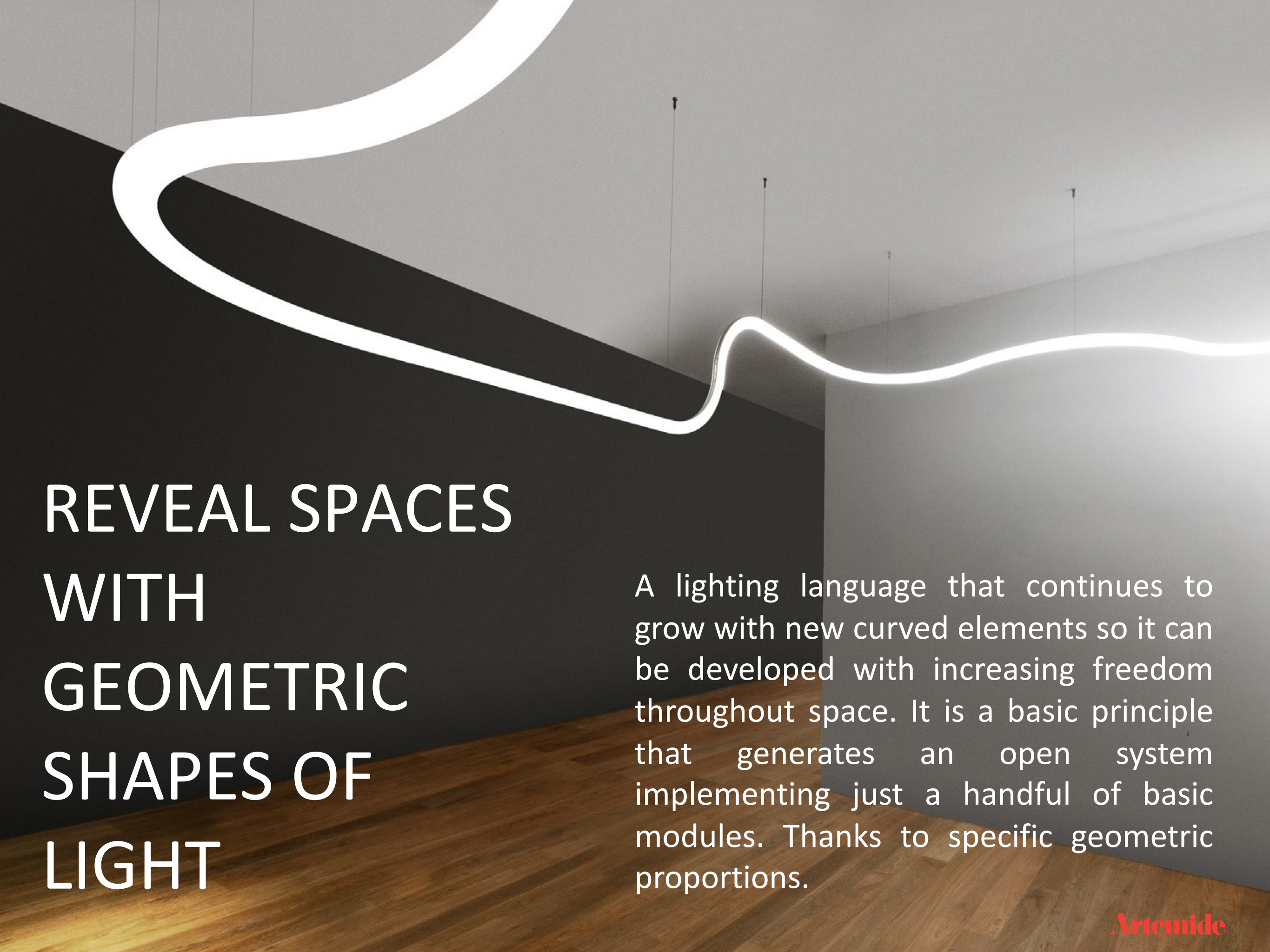

REVEAL SPACES WITH GEOMETRIC SHAPES OF LIGHT

A lighting language that continues to grow with new curved elements so it can be developed with increasing freedom throughout space. It is a basic principle that generates an open system implementing just a handful of basic modules. Thanks to specific geometric proportions.

LIGHT FOLLOWS SPACES



KPMB ARCHITECTS OFFICE, TORONTO, CANADA

Project: KPMB Architects Office Photo: Maris Mezulis Photography

Artemide

DESIGN PRODUCES A HIGH-EFFICIENCY LIGHT WITHOUT SHADOWS

Mixing chamber

Patent pending
MI102016000025996

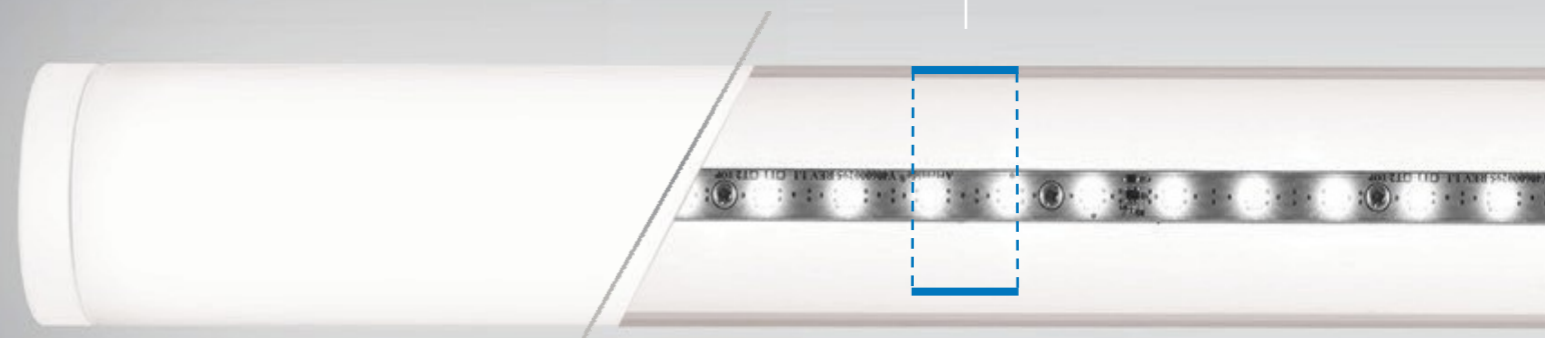
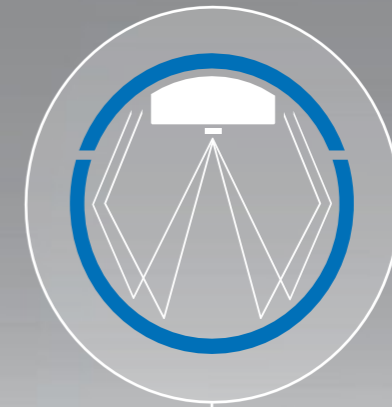

MATERIALS

Extruded aluminum structure
Injection molded plastic material diffuser

DIMENSIONS

Tube \varnothing 5cm
Linear modules 60cm / 120cm / 180cm
Max suspension length 150cm
360° degree light emission

DRIVER HOUSING DIMENSIONS

L: 12" (30.6 cm) x 5^{5/16}" (13.5 cm) x H: 1^{11/16}" (4.25 cm)

VOLTAGE

Constant voltage 120V-277V

TOTAL POWER

from 8W (curve module)
up to 33W (180 cm linear module)

DELIVERED LUMINOUS FLUX

from 612lm (90° DOWN curve module)
up to 2977lm (180 cm linear module)

LED

3000K
3500K

80CRI

DIMMABLE 0-10V

SYSTEM COMPOSITION

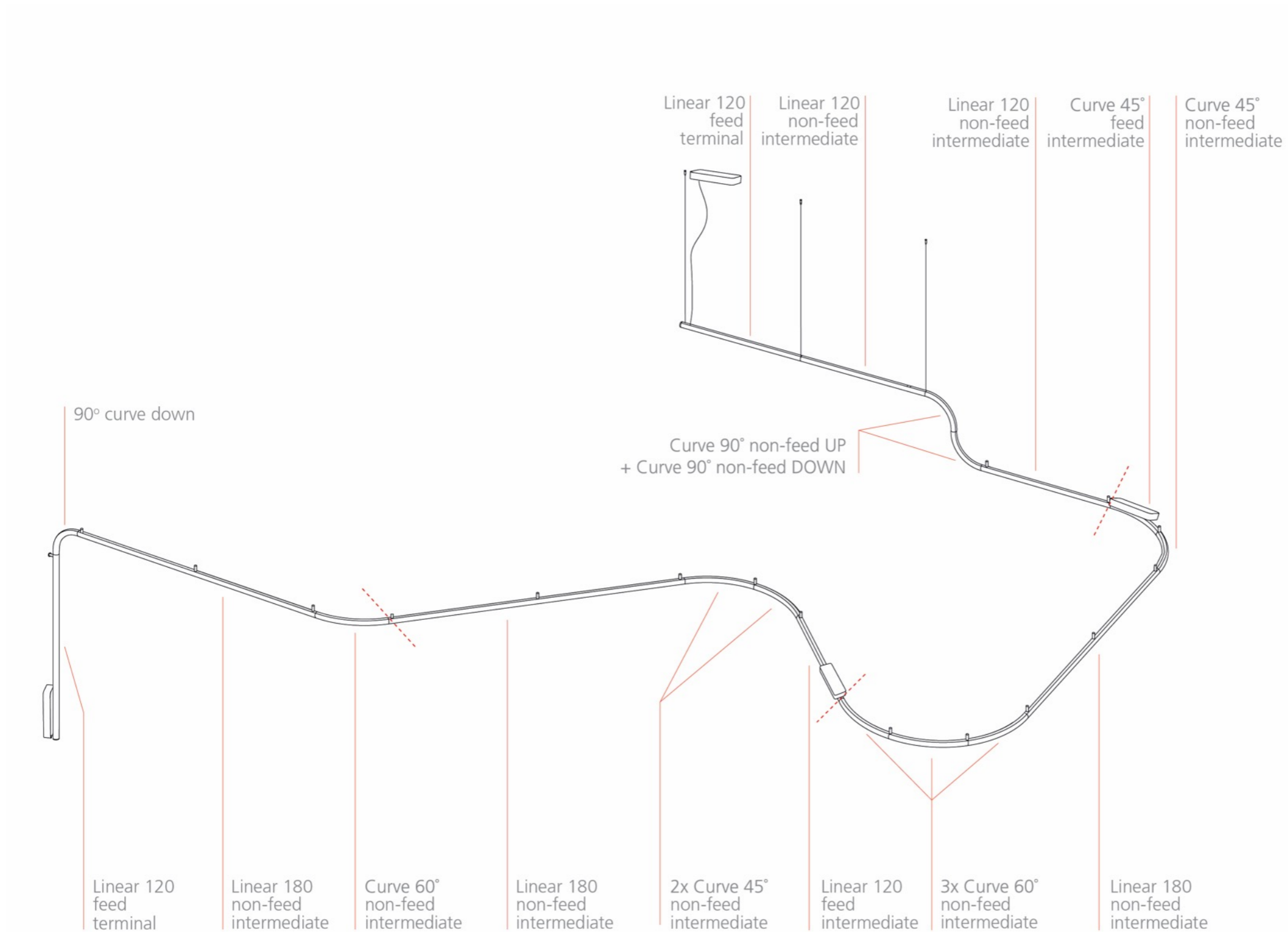

SYSTEM COMPOSITION

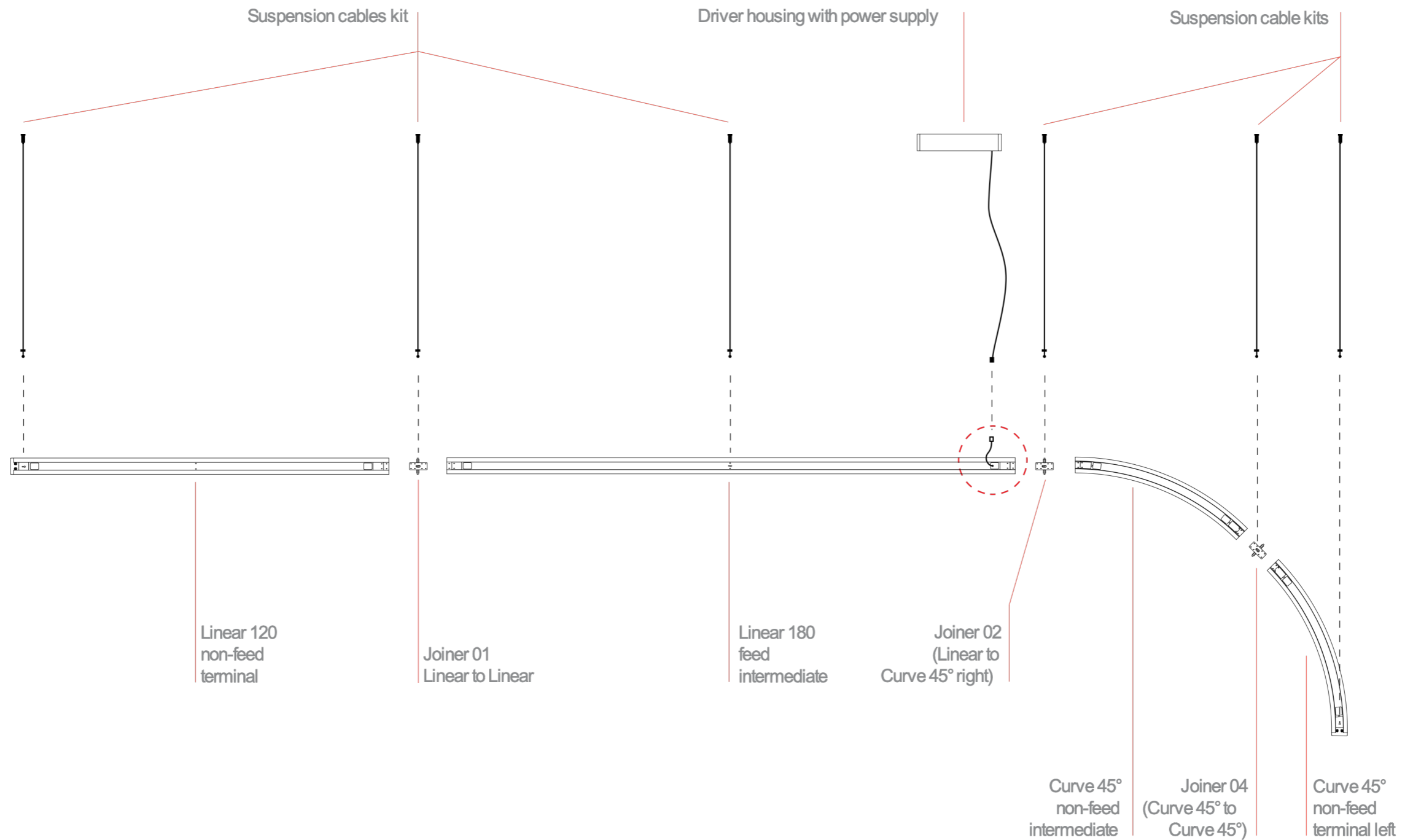

SYSTEM COMPOSITION

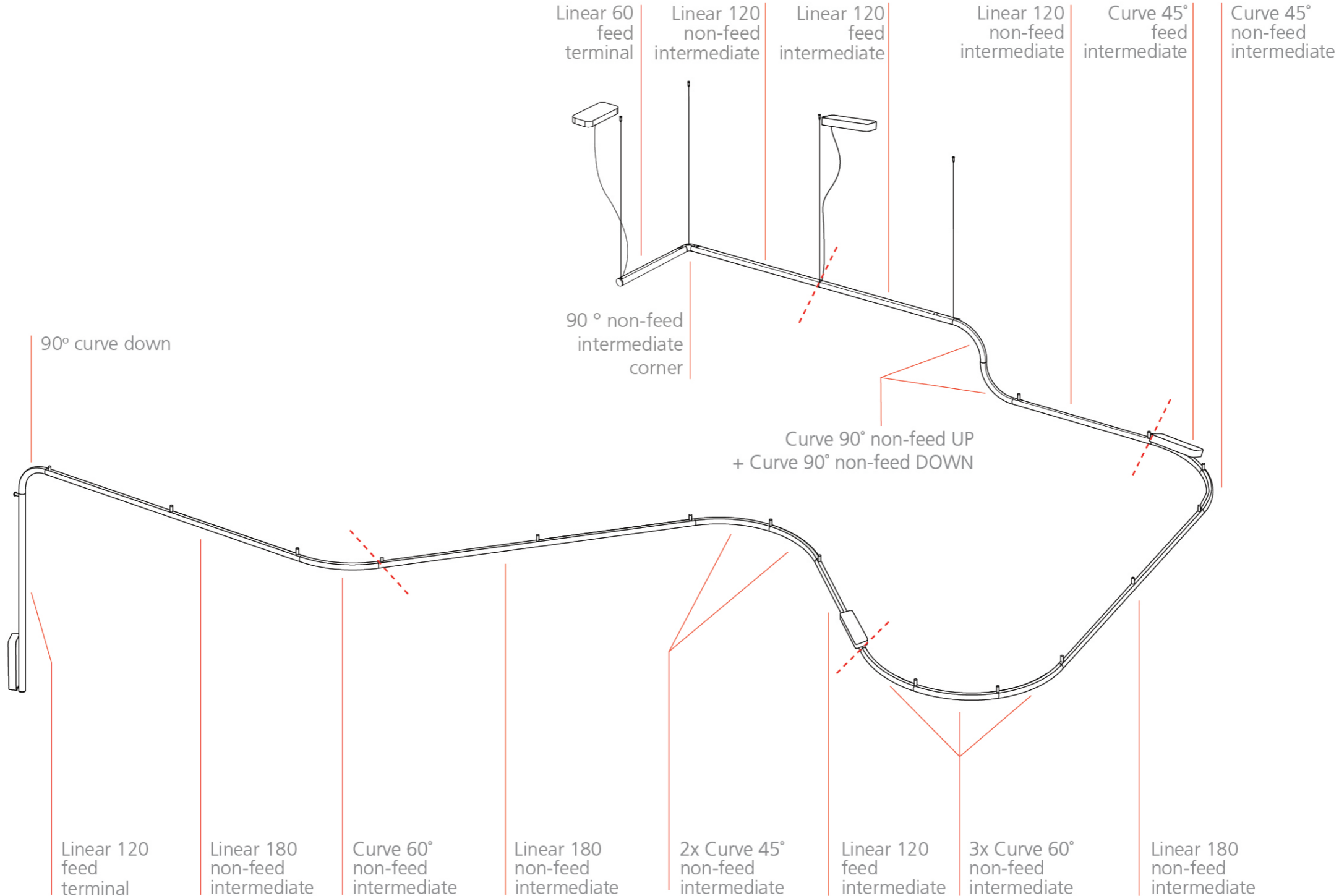

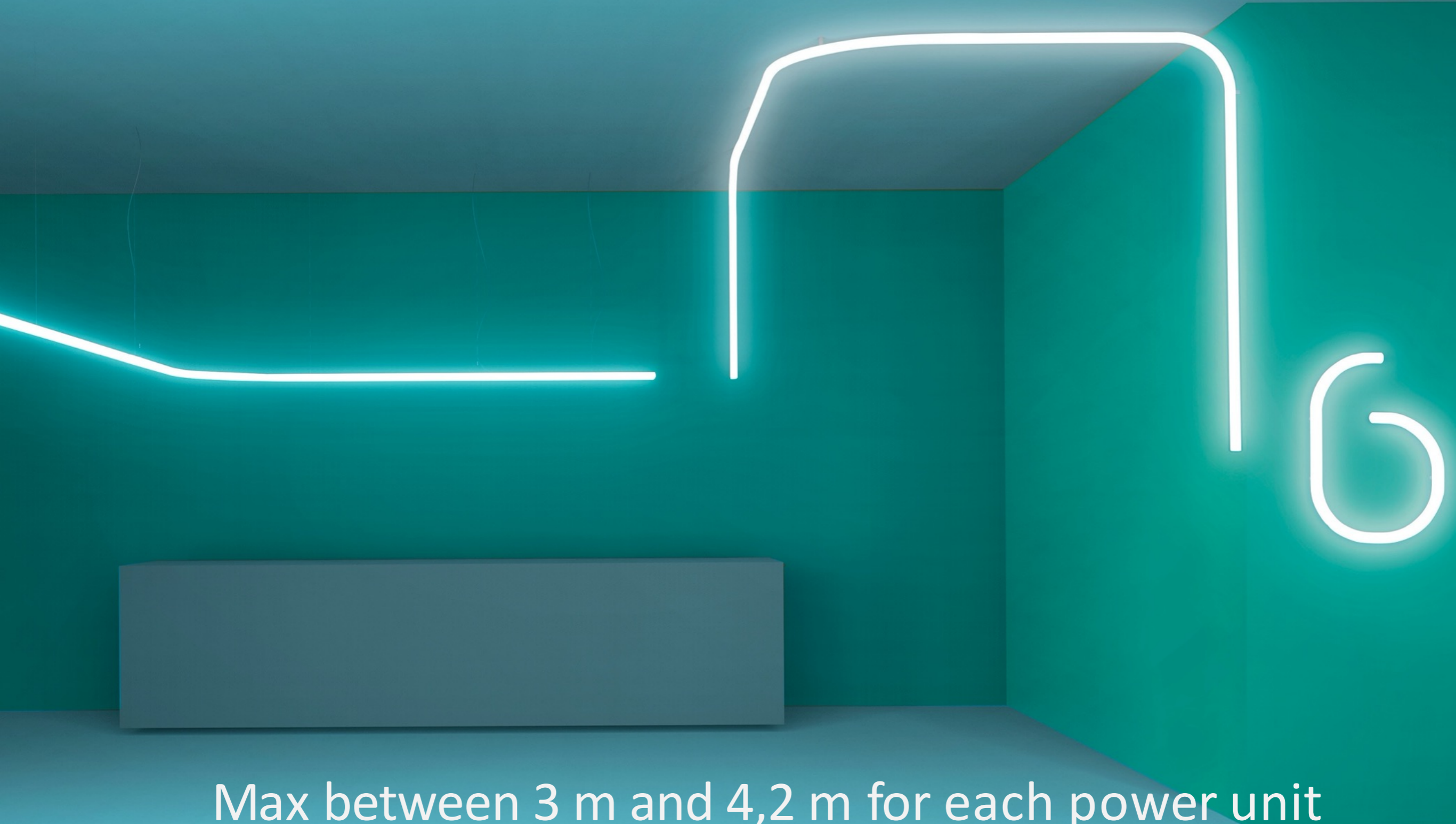

Max between 3 m and 4,2 m for each power unit

85W_ 24V _ Dimmable 0-10

SYSTEM MODULES SUSPENSION

SUSPENSION - LINEAR ELEMENTS

60 TERMINAL

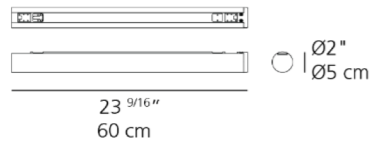

60 INTERMEDIATE

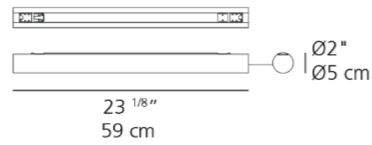

120 TERMINAL

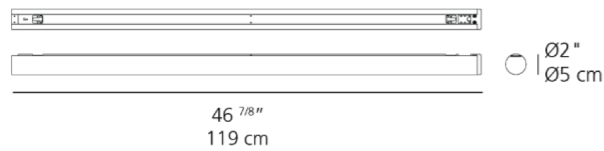

120 INTERMEDIATE

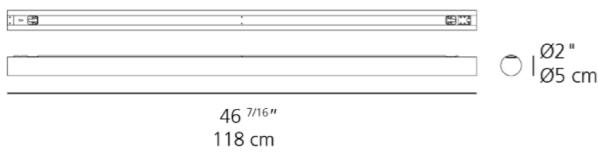

180 TERMINAL

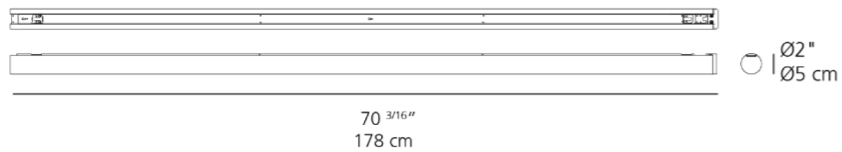

180 INTERMEDIATE

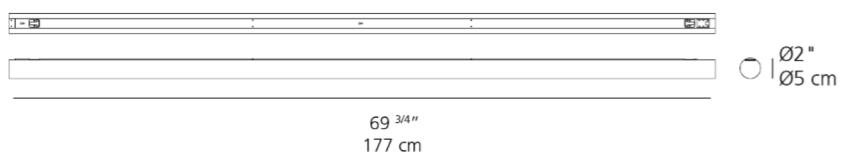

SUSPENSION - CURVE ELEMENTS

90° VECRTICAL UP

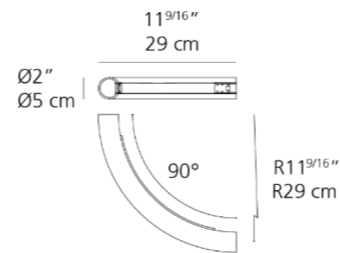

90° VECRTICAL DOWN

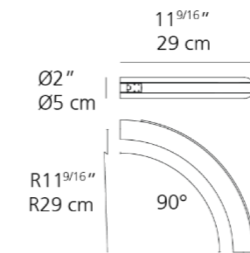

45° LEFT TERMINAL

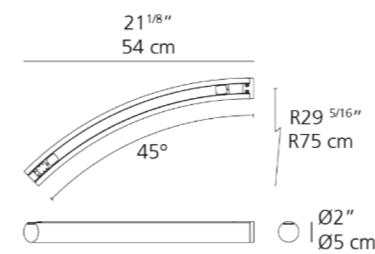

60° LEFT TERMINAL

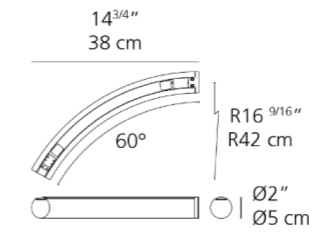

45° RIGHT TERMINAL

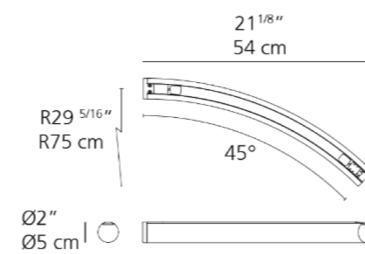

60° RIGHT TERMINAL

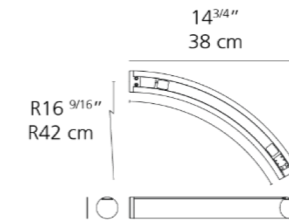

45° INTERMEDIATE

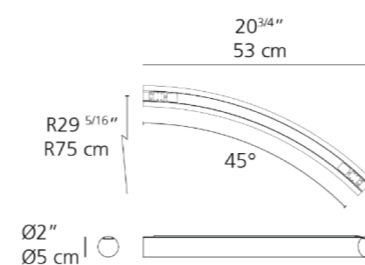

60° INTERMEDIATE

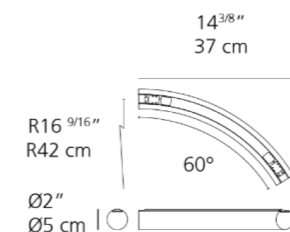

SYSTEM MODULES SUSPENSION

ALPHABET OF LIGHT - SUSPENSION SYSTEM

CURVED ELEMENTS TERMINAL

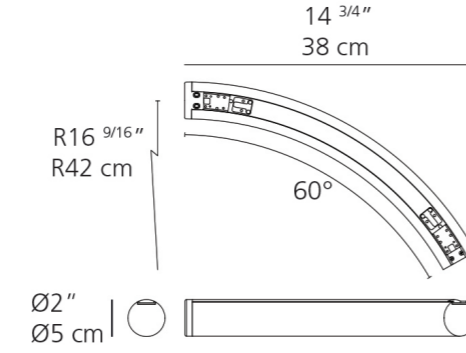
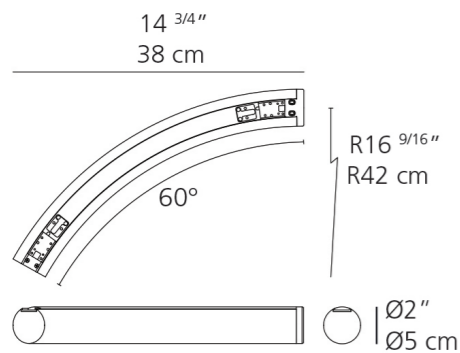
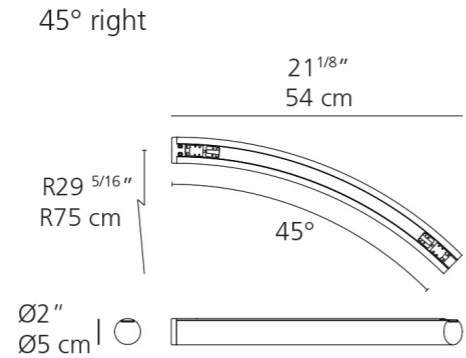
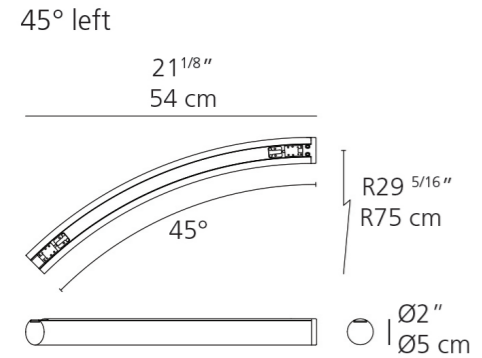

CURVED ELEMENTS INTERMEDIATE

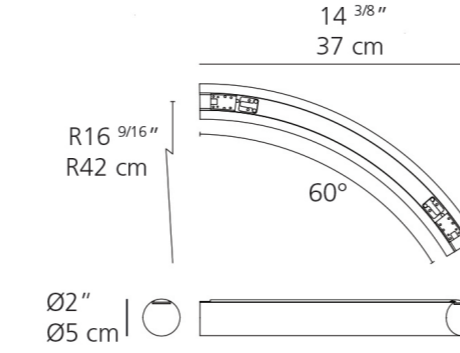
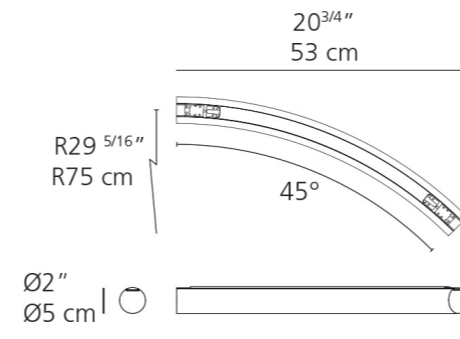

90° VERTICAL UP

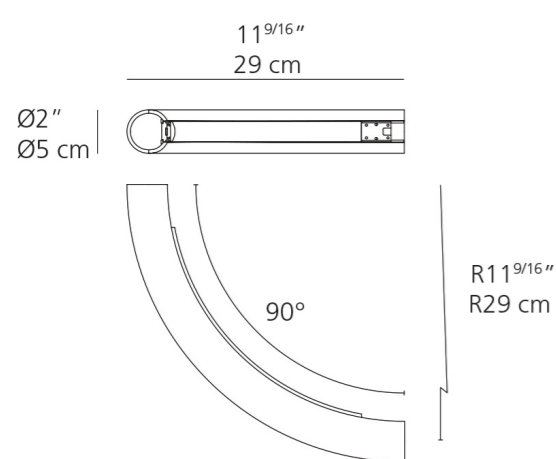

90° VERTICAL DOWN

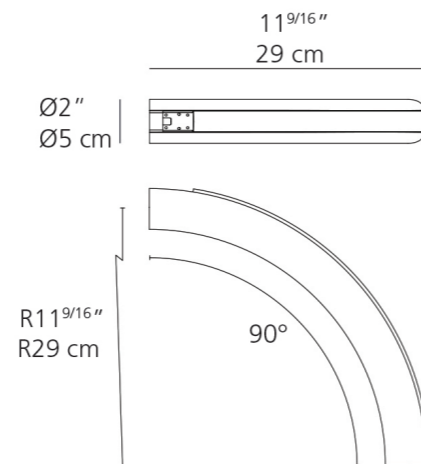

90° INTERMEDIATE HORIZONTAL CORNER

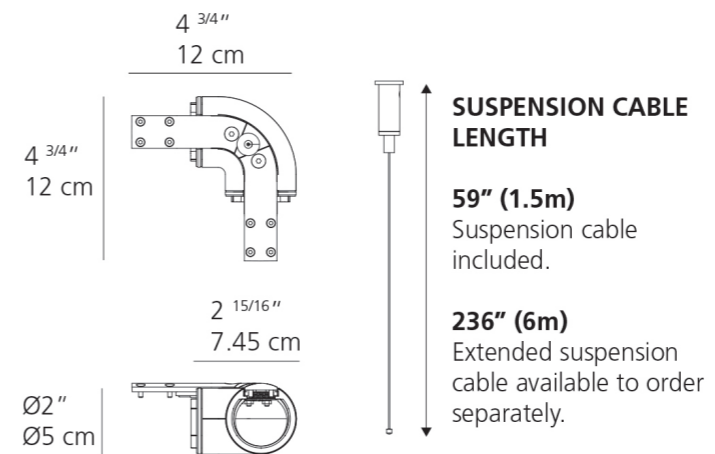

SYSTEM MODULES WALL/CEILING

WALL/CEILING - LINEAR ELEMENTS

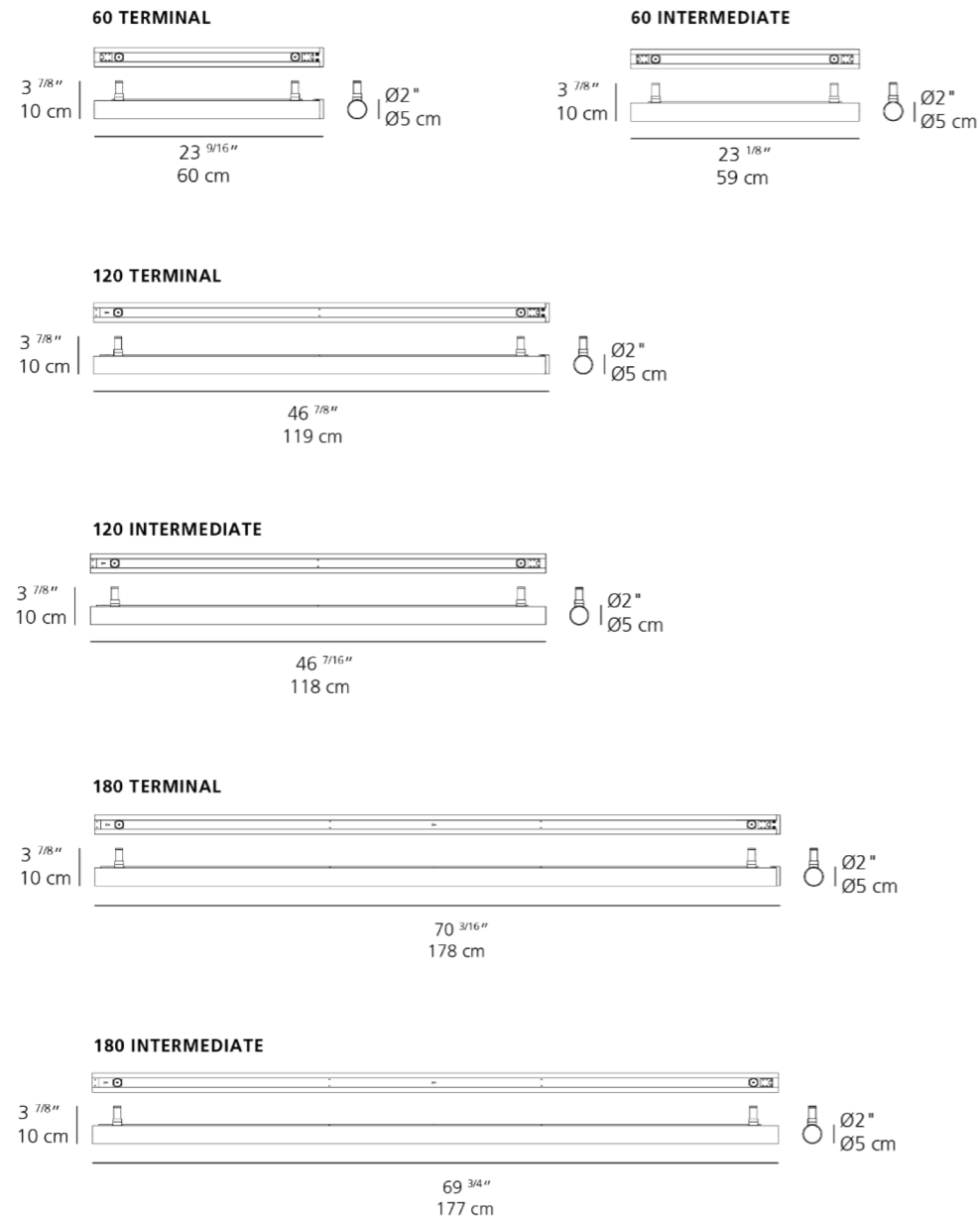

WALL/CEILING - CURVE ELEMENTS

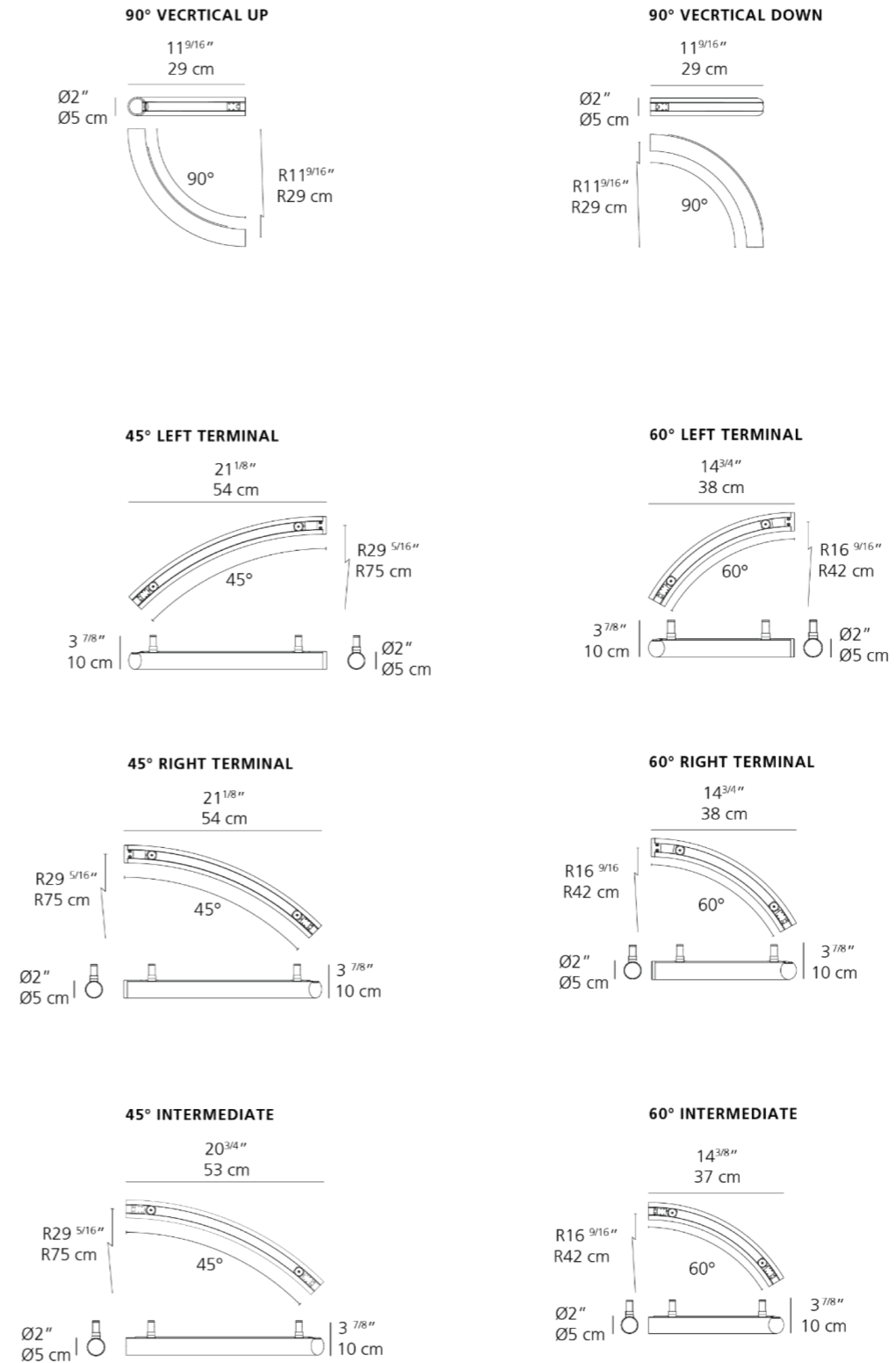

SYSTEM MODULES SURFACE

ALPHABET OF LIGHT - SURFACE SYSTEM

LINEAR ELEMENTS TERMINAL

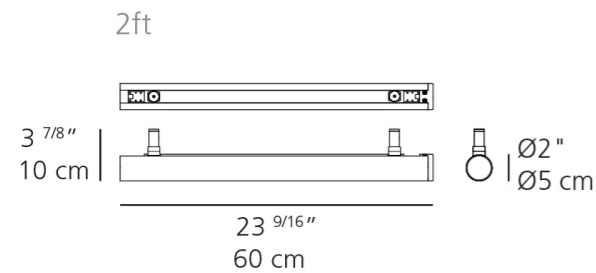

LINEAR ELEMENTS INTERMEDIATE

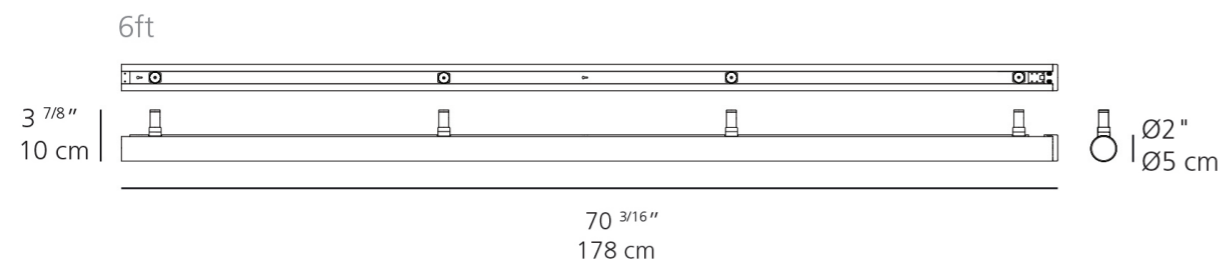
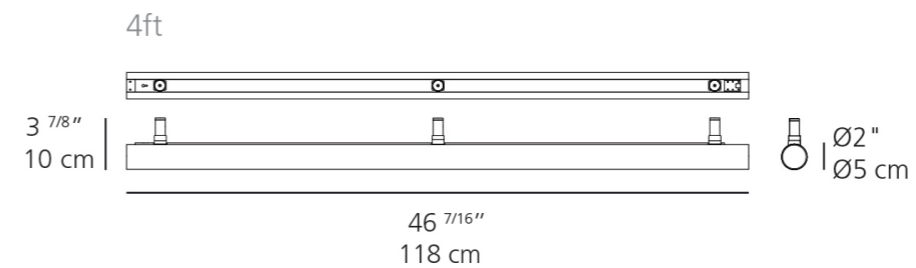
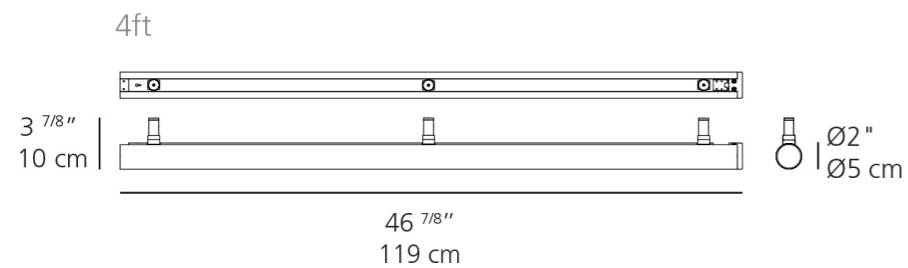
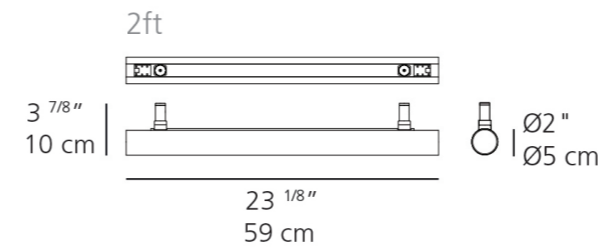

LINEAR ELEMENTS INTERMEDIATE

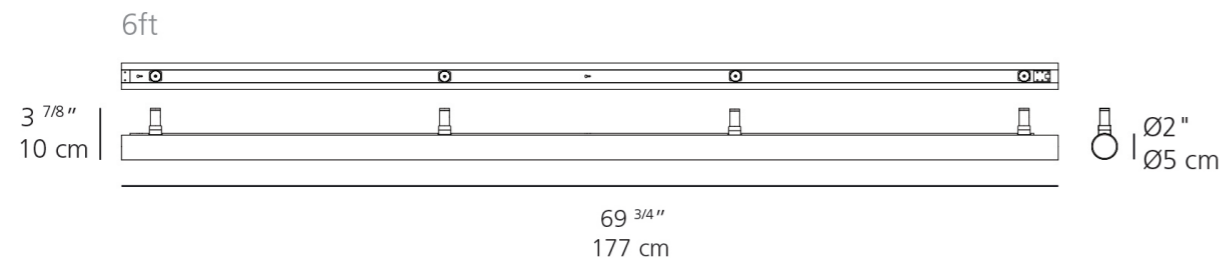

SYSTEM MODULES SURFACE

ALPHABET OF LIGHT - SURFACE SYSTEM

CURVED ELEMENTS TERMINAL

45° left

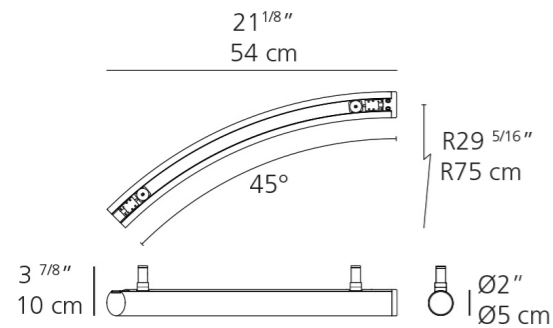

45° right

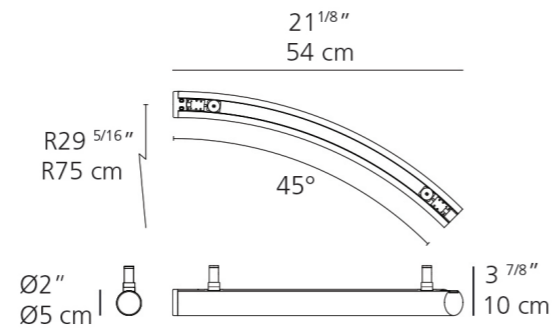

14 3/4"
38 cm

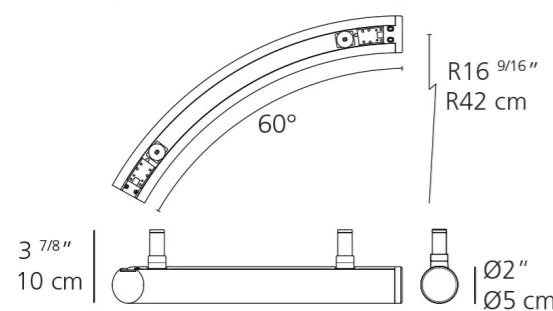

14 3/4"
38 cm

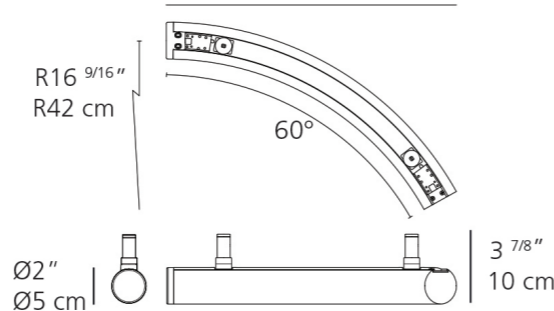

CURVED ELEMENTS INTERMEDIATE

20 3/4"
53 cm

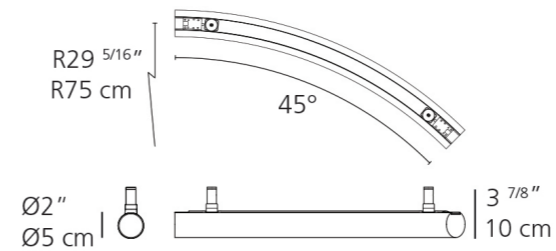

14 3/8"
37 cm

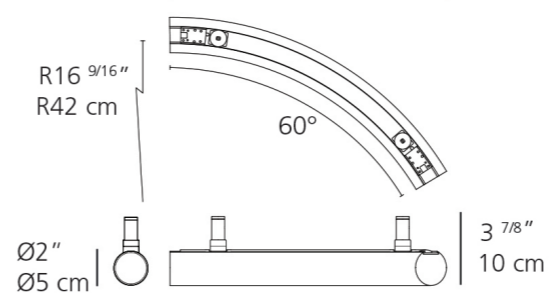

90° VERTICAL UP

11 9/16"
29 cm

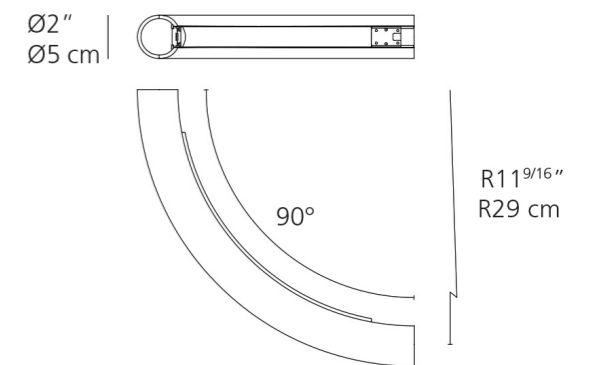

90° VERTICAL DOWN

11 9/16"
29 cm

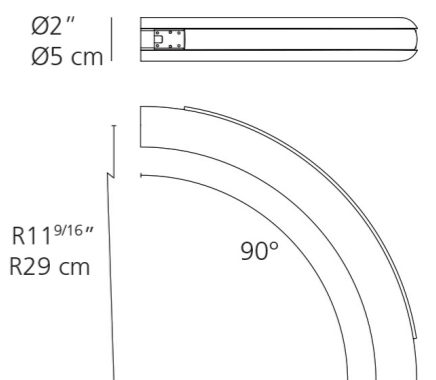

90° INTERMEDIATE CORNER

4 3/4"
12 cm

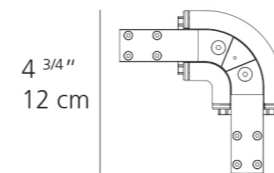

2 15/16"
7.45 cm





SLEEK

Alphabet of Light is composed of a series of seamless joiners and linear or curved models that fit together to create one piece with a seamless, even light.

SYSTEM MODULE Joiners

JOINER 1
LINEAR TO LINEAR
USC-2250010A



JOINER 2
LINEAR TO CURVE 45° - J
USC-2251010A

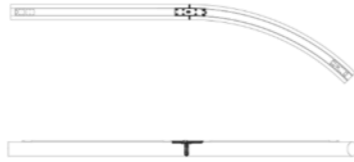

JOINER 3
LINEAR TO CURVE 45° - L
USC-2252010A

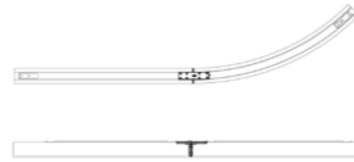

JOINER 4
CURVE 45° TO CURVE 45° - C
USC-2255010A

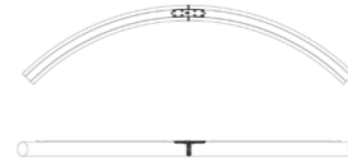

JOINER 5
LINEAR TO CURVE 60° - J
USC-2253010A

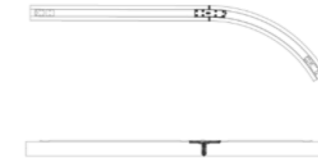

JOINER 6
LINEAR TO CURVE 60° - L
USC-2254010A

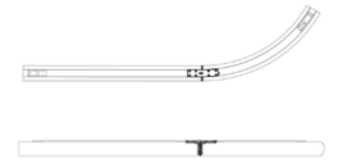

JOINER 7
CURVE 60° TO CURVE 60° - C
USC-2256010A

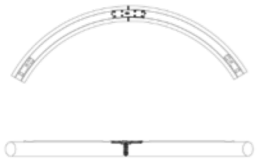

JOINER 8
CURVE 60° TO CURVE 45° - Z
USC-2257010A

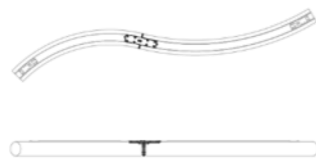

JOINER 9
CURVE 45° TO CURVE 45° - S
USC-2260010A

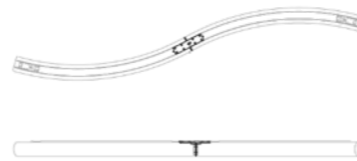

JOINER 10
CURVE 60° TO CURVE 60° - Z
USC-2259010A

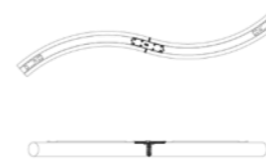

JOINER 11
CURVE 60° TO CURVE 45° - C
USC-2261010A

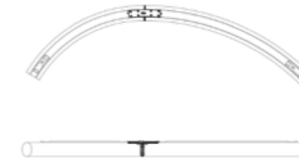

JOINER 12
CURVE 45° TO CURVE 60° - C
USC-2262010A

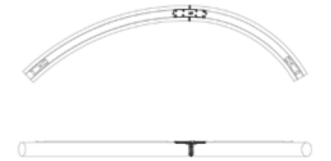

JOINER 13
90° DOWN TO 90° UP
USC-2263010A

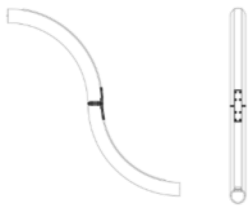

JOINER 14
LINEAR TO 90° UP
USC-2264010A

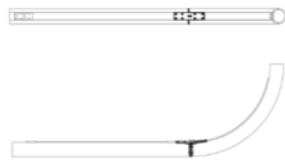

JOINER 15
LINEAR TO 90° DOWN
USC-2265010A

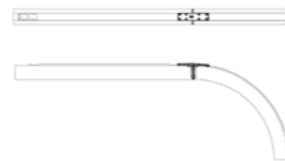

JOINER 16
CURVE 45° TO CURVE 60° - S
USC-2258010A

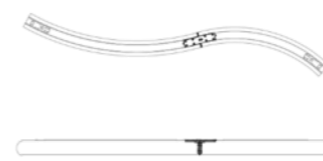

JOINER 17
CURVE 45° TO CURVE 45° - Z
USC-2269010A

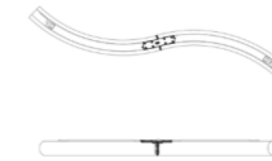

JOINER 18
CURVE 60° TO CURVE 60° - S
USC-2270010A

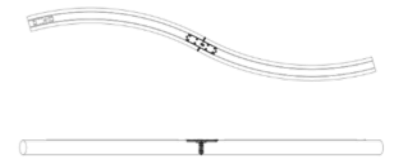

SYSTEM DRIVER HOUSINGS

SUSPENSION DRIVER HOUSING

Driver housing for suspension module, feed wire for suspension module.

2267018A : 59" feed wire – 1,5m feed wire

2267018AEXT : 236" feed wire – 6m feed wire

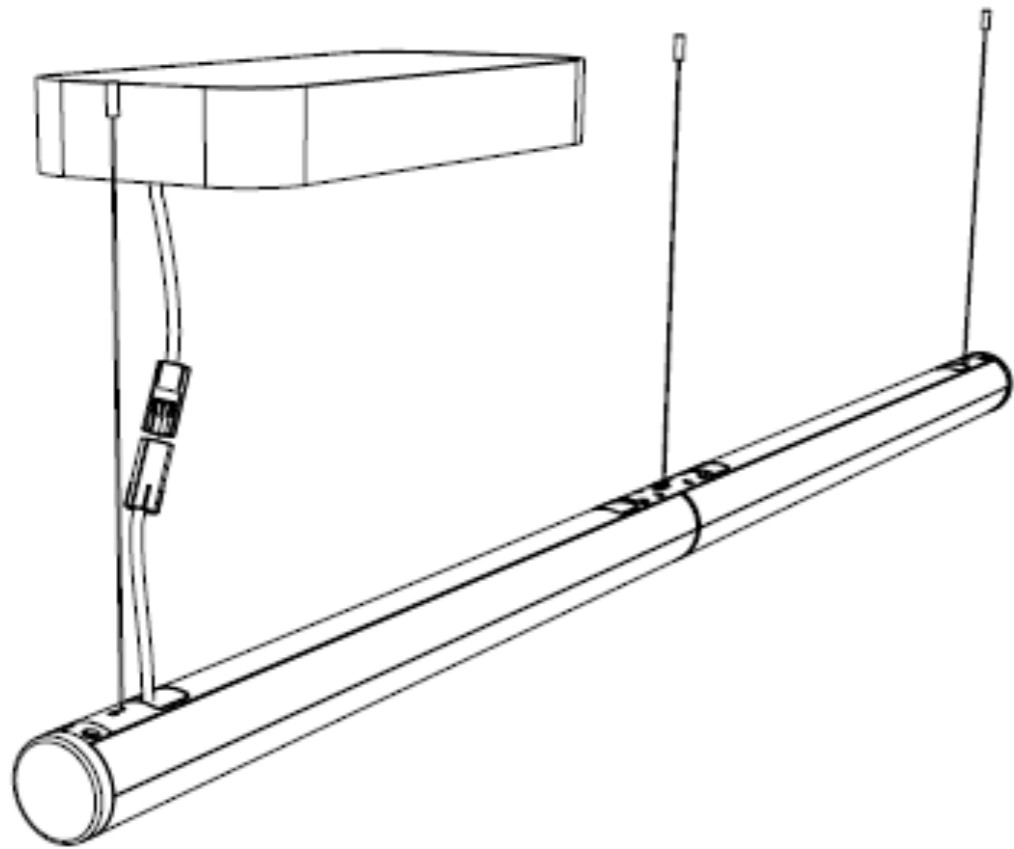

WALL-CEILING DRIVER HOUSING

Driver housing for wall/ceiling module.

2268018A

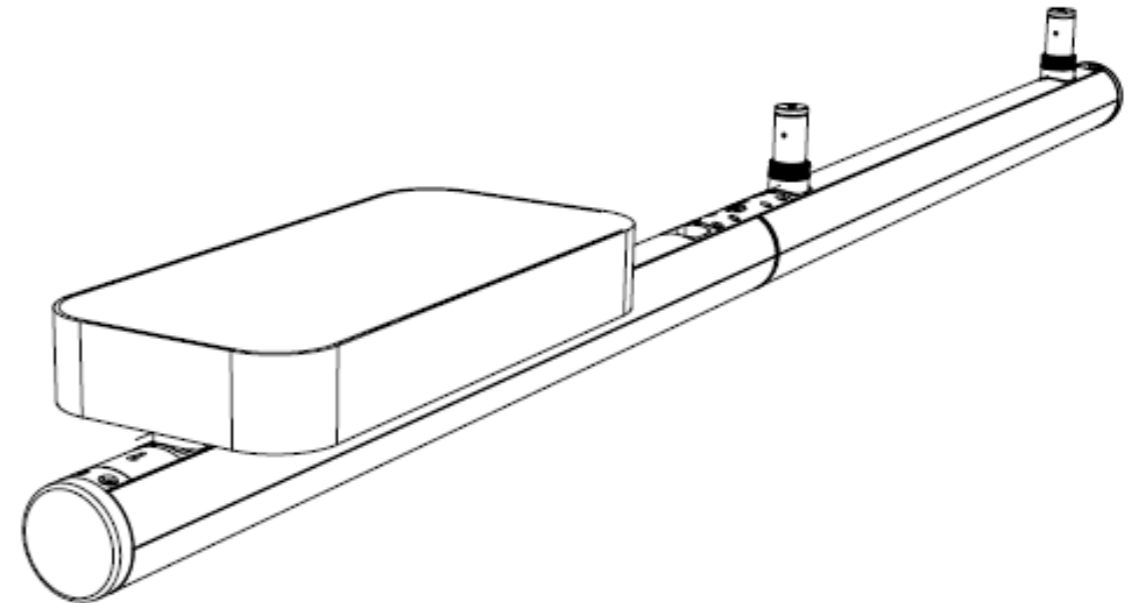

SYSTEM DRIVER HOUSINGS

DRIVER HOUSING FOR SUSPENSION MODULES

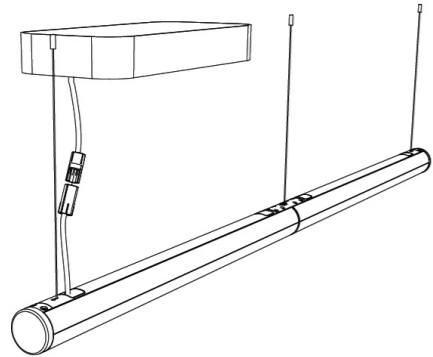

LOCALLY FEEDING THE SECTION
Feed module + driver housing

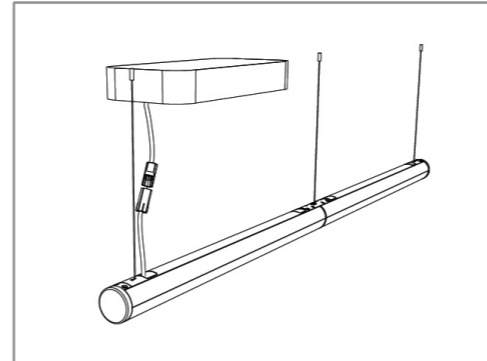

REMOTELY FEEDING THE SECTION
Feed module + canopy for remote feed
+ AOL Driver Enclosure

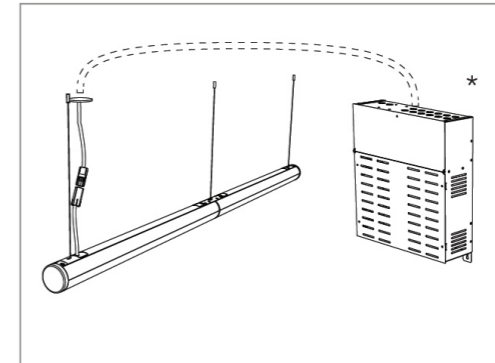

DRIVER HOUSING FOR WALL / CEILING MODULES

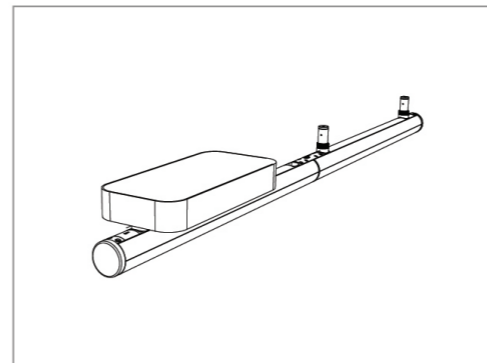
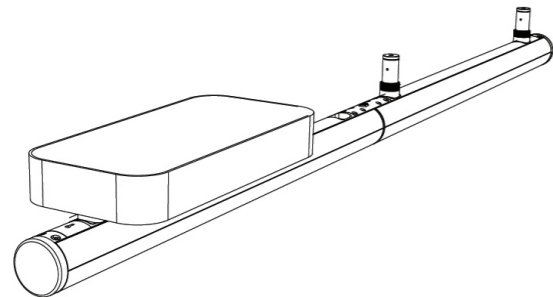

Remote feed module + AOL Driver
Enclosure

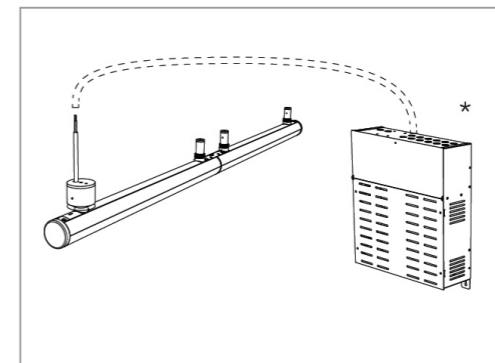

REMOTE FEED CANOPY FOR AOL DRIVER
ENCLOSURE FOR WALL / CEILING MODULES AND
SUSPENSION

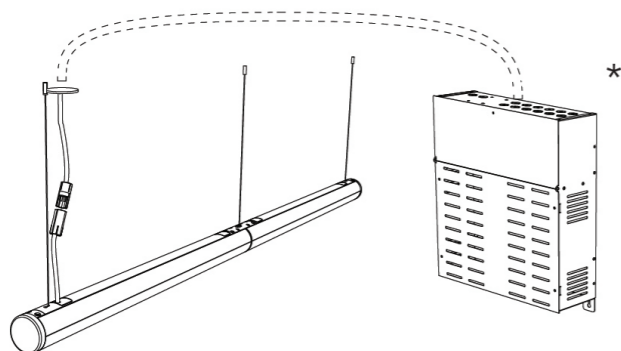

REMOTE FEED CANOPY

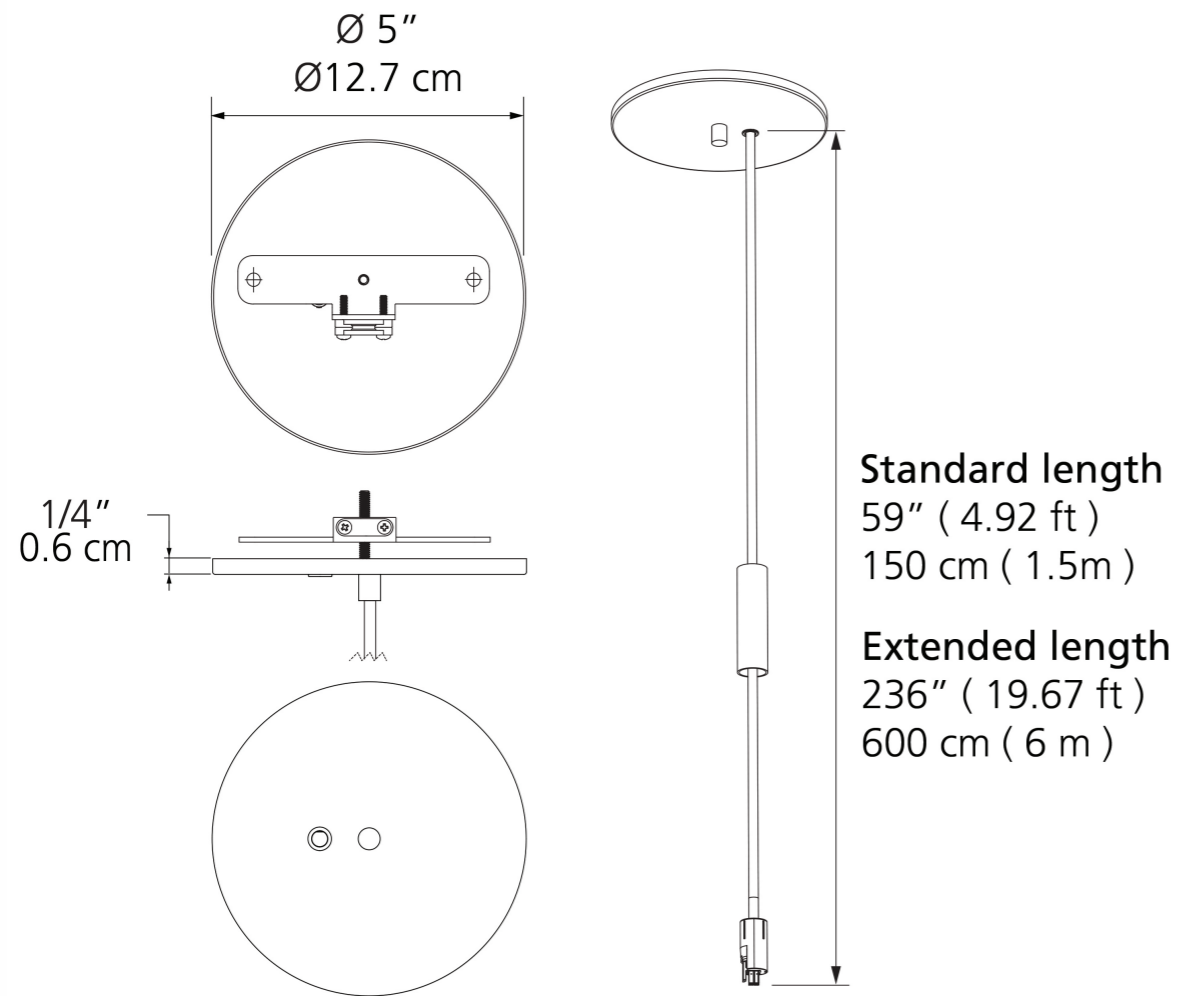

COMBINATIONS

CURVE 45° / LINEAR 120 / LINEAR 180



CURVE 90°
(2 x curve 45°)

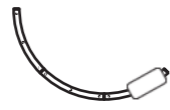

CURVE 135°
(3 x curve 45°)



CURVE 180°
(4 x curve 45°)



CURVE 225°
(5 x curve 45°)

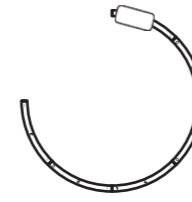

CURVE 270°
(6 x curve 45°)



CURVE 315°
(7 x curve 45°)

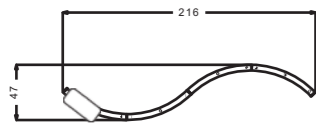

WAVE 2.15m
(4 x curve 45°)

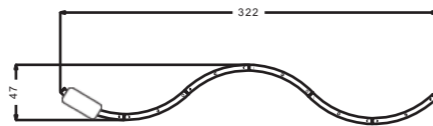

WAVE 3.20m
(6 x curve 45°)

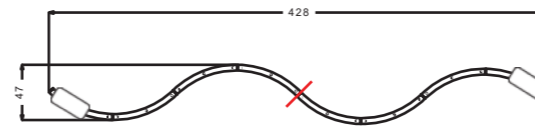

WAVE 4.25 m
(8 x curve 45°)

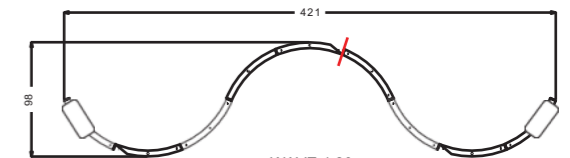

WAVE 4.20 m
(9 x curve 45°)

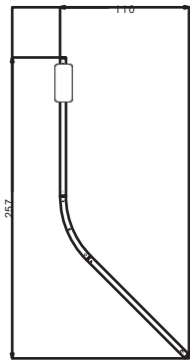

LINEAR 120 AT 45°
(2 x linear 120 + 1 x curve 45°)

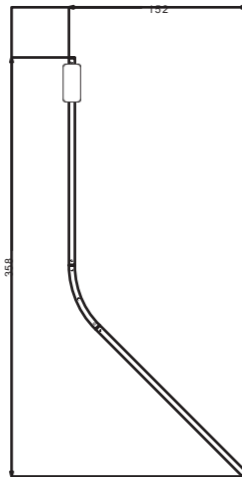

LINEAR 180 AT 45°
(2 x linear 180 + 1 x curve 45°)

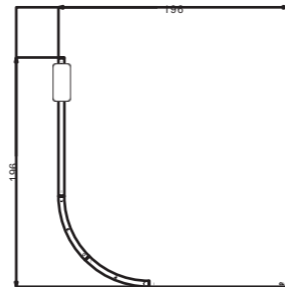

LINEAR 120 AT 90°
(2 x linear 120 + 2 x curve 45°)

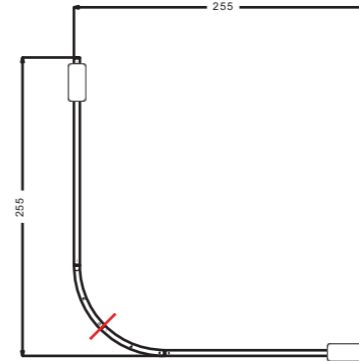

LINEAR 180 AT 90°
(2 x linear 180 + 2 x curve 45°)

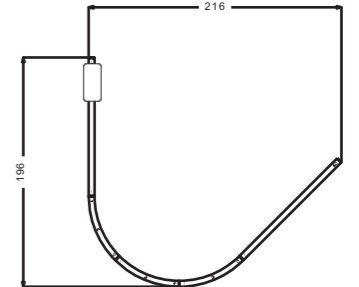

LINEAR 120 AT 135°
(2 x linear 180 + 3 x curve 45°)

COMBINATIONS

CURVE 45° / LINEAR 120 / LINEAR 180

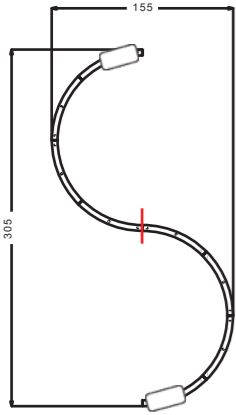

S1
(8 x curve 45°)

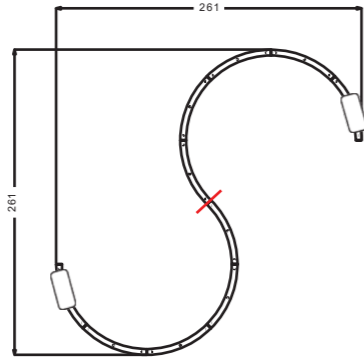

S2
(10 x curve 45°)

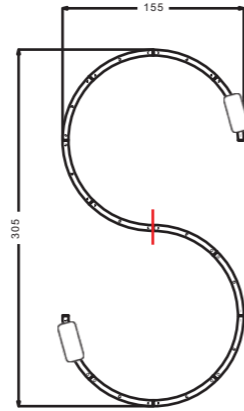

S3
(12 x curve 45°)

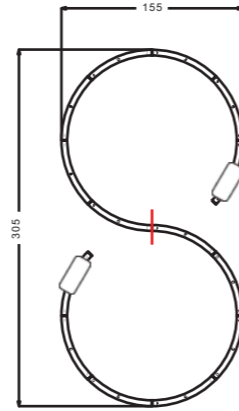

S4
(14 x curve 45°)

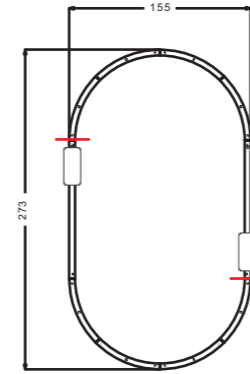

OVAL 120
(2x linear 120 + 8 x curve 45°)

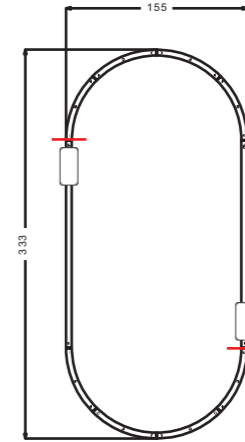

OVAL 180
(2x linear 180 + 8 x curve 45°)

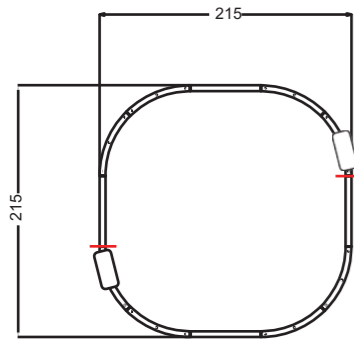

SQUARE 60
(4 x linear 60 + 8 x curve 45°)

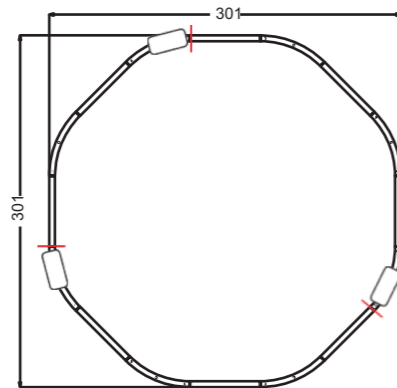

OCTAGON 60
(8 x linear 60 + 8 x curve 45°)

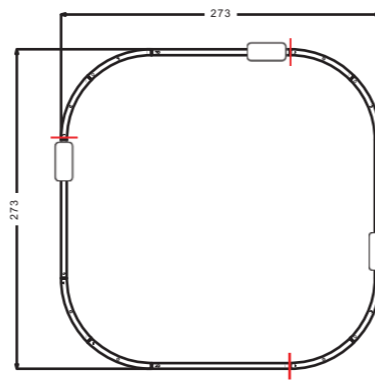

SQUARE 120
(4 x linear 120 + 8 x curve 45°)

COMBINATIONS

CURVE 60° / LINEAR 120 / LINEAR 180



CURVE 180°
(3 x curve 60°)



CURVE 240°
(4 x curve 60°)



CURVE 300°
(5 x curve 60°)

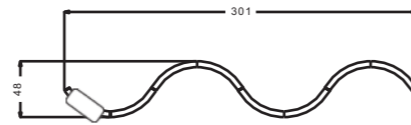

WAVE 3.00m
(8 x curve 60°)

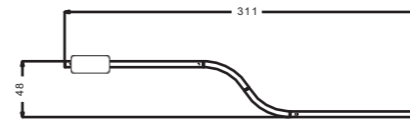

WAVE LINEAR 3.10 m
(2 x linear 120 + 2 x curve 60°)

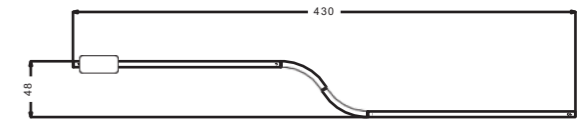

WAVE LINEAR 4.30 m
(2 x linear 180 + 2 x curve 60°)

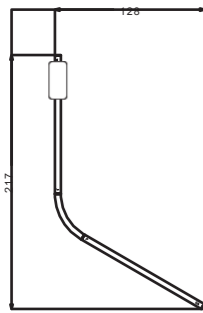

LINEAR 120 AT 60°
(2 x linear 120 + 1 x curve 60°)

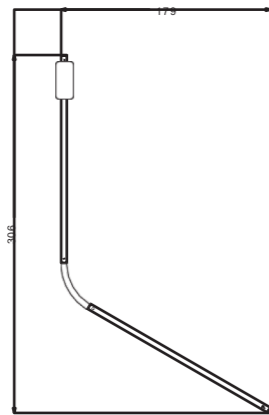

LINEAR 180 AT 60°
(2 x linear 180 + 1 x curve 60°)

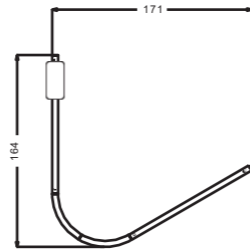

LINEAR 120 AT 120°
(2 x linear 120 + 2 x curve 60°)

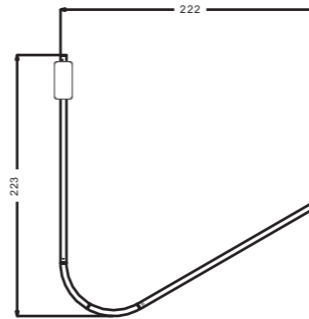

LINEAR 180 AT 120°
(2 x linear 180 + 2 x curve 60°)

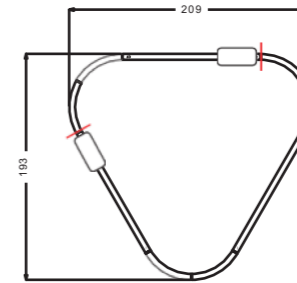

TRIANGLE 120
(3 x linear 120 + 6 x curve 60°)

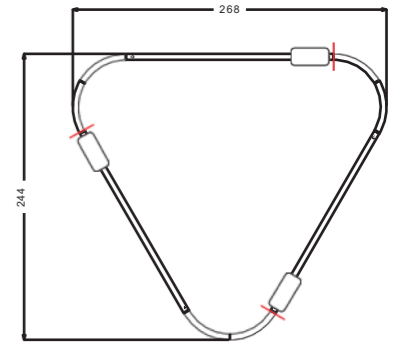

TRIANGLE 180
(3 x linear 180 + 6 x curve 60°)

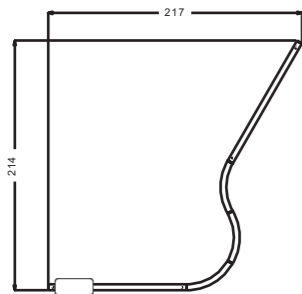

WAVE LINEAR 120
(2 x linear 120 + 3 x curve 60°)

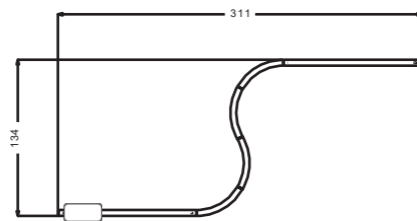

WAVE LINEAR 3.10 m
(2 x linear 120 + 4 x curve 60°)

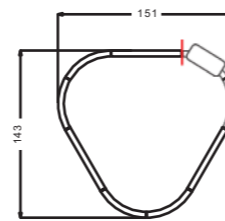

TRIANGLE 60
(3 x linear 60 + 6 x curve 60°)

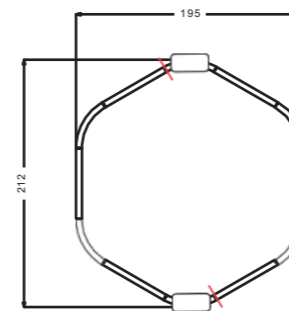

HEXAGON 60
(6 x linear 60 + 6 x curve 60°)

COMBINATIONS

CURVE 60° / LINEAR 120 / LINEAR 180

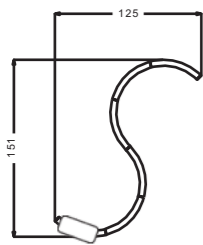

S1
(6 x curve 60°)

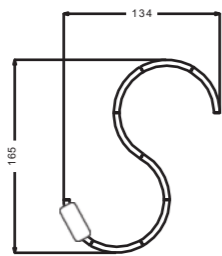

S2
(8 x curve 60°)

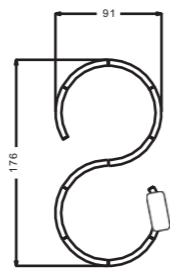

S3
(10 x curve 60°)

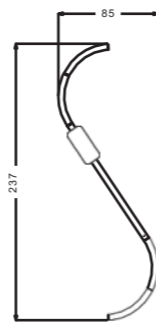

S4 120
(1 x linear 120 + 4 x curve 60°)

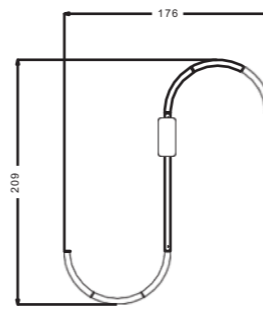

S5 120
(1 x linear 120 + 6 x curve 60°)

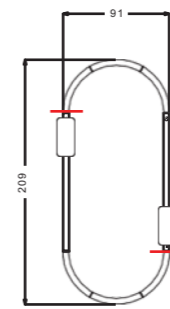

OVAL 120
(2 x linear 120 + 6 x curve 60°)

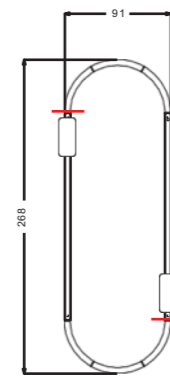

OVAL 180
(2 x linear 180 + 6 x curve 60°)

COMBINATIONS

CURVE 60° / CURVE 45°

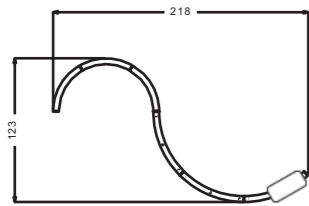

WAVE 1
(3 x curve 60° + 3 x curve 45°)

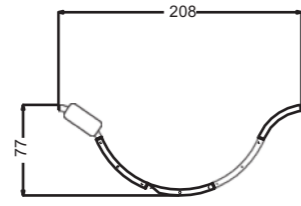

WAVE 2
(2 x curve 60° + 3 x curve 45°)

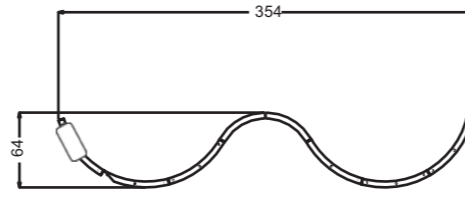

WAVE 3
(2 x curve 60° + 6 x curve 45°)

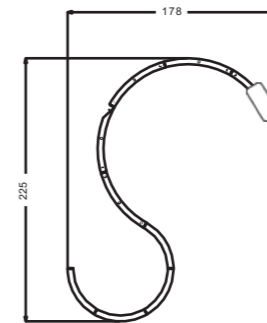

WAVE 4
(4 x curve 60° + 4 x curve 45°)

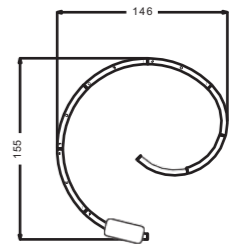

SPIRAL 1
(3 x curve 60° + 5 x curve 45°)



HEADQUARTERS OF ZOGENIX , EMERYVILLE, CA, USA

Project: Revel Architecture & Design. Lighting Solution: Lighting Systems. Photo: Emily Hagopian



HEADQUARTERS OF ZOGENIX , EMERYVILLE, CA, USA

Project: Revel Architecture & Design. Lighting Solution: Lighting Systems. Photo: Emily Hagopian

Artemide



iQ OFFICES, VANCOUVER, CANADA

Project: IQ Offices. Lighting Solution: EDP. Photo: INFRAME

Artemide



iQ OFFICES, VANCOUVER, CANADA

Project: IQ Offices. Lighting Solution: EDP. Photo: INFRAME

Artemide



iQ OFFICES, VANCOUVER, CANADA

Project: IQ Offices. Lighting Solution: EDP. Photo: INFRAME

Artemide



BIG OFFICE, BROOKLYN, NY, USA
Project: Bjarke Ingels Group



BIG OFFICE, BROOKLYN, NY, USA

Project: Bjarke Ingels Group Photo: Max Touhey

Artemide®



BIG OFFICE, BROOKLYN, NY, USA

Project: Bjarke Ingels Group Photo: Max Touhey

Artemide



WEGROW, NEW YORK, NY, USA

Project: Bjarke Ingels Group

Artemide



WEGROW, NEW YORK, NY, USA

Project: Bjarke Ingels Group

Artemide

ALPHABET OF LIGHT

BIG - Bjarke Ingels Group



PATENT PENDING MI102016000025996

PATENT PENDING 102017000037606



Artemide
App
Compatible

TO WRITE THE LIGHT

abcdefghijklmnopqrstuvwxyz
abcdefghijklmnopqrstuvwxyz
abcdefghijklmnopqrstuvwxyz

ABCDEFGHIJKLMNOPQRSTUVWXYZ
ABCDEFGHIJKLMNOPQRSTUVWXYZ
ABCDEFGHIJKLMNOPQRSTUVWXYZ

PRODUCES A HIGH-EFFICIENCY LIGHT WITHOUT SHADOWS

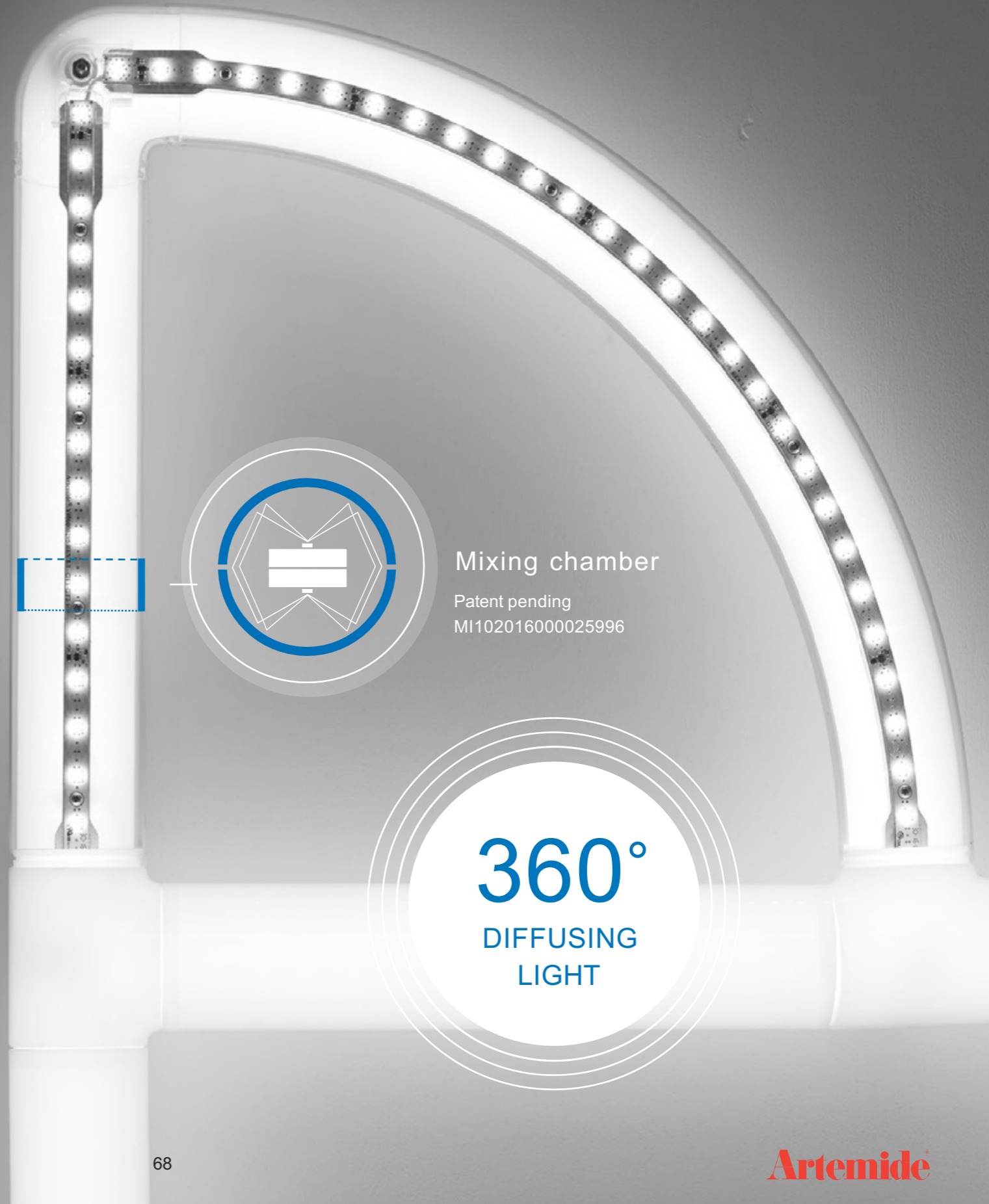

Mixing chamber
Patent pending
MI102016000025996

LED

3000K

80CRI

360°
DIFFUSING
LIGHT



MEANINGFUL

BIG designed a new font, an alphabet that can be used to write and express one's thoughts, establish an identity and guide visitors through a space using light.

It can help give shape to a wide range of locations and public spaces, from hotels and offices to universities and hospitals.



SEAMLESS
TRANSITIONS
BETWEEN
ALL MODULES



ELECTRO MECHANICAL CONNECTIONS

L Joiner



Linear Joiner



T Joiner



Patent Pending
102017000037606

UPPERCASE

A B C D E F G H I J K L M N O

P Q R S T U V W X Y Z Æ Ø Â ß

LOWERCASE

a b c d e f g h i j k l m n o

p q r s t u v w x y æ ø ñ ß

NUMBERS

0 1 2 3 4 5 6 7 8 9

AOL Uppercase Wall

PERFORMANCE

LIGHT SOURCE	LED
LIGHT DISTRIBUTION	Direct / Indirect
COLOR RENDERING INDEX	80CRI
COLOR TEMPERATURE	3000K 

FEATURES

FUNCTION	Indoor signage lighting
BODY FINISH	Opal diffusing PMMA
JOINT MODULES FINISH	Opal diffusing PMMA
MOUNTING	Positioning template included
VOLTAGE	24VDC
CERTIFICATIONS	

PHOTOMETRIC DISTRIBUTION

For most updated photometric data files, please visit the product page at www.artemide.net

ALPHABET CONFIGURATOR

Contact our sales agents for more information about our configuration software.

	POWER CONSUMPTION (W)	DELIVERED LUMENS (lm)	EFFICACY (lm/W)	EFFICIENCY (%)
A	30W	2011lm	67.0	69%
B	31W	2156lm	69.5	69%
C	20W	1296lm	64.8	69%
D	29W	2011lm	69.3	69%
E	26W	1651lm	63.5	69%
F	19W	1221lm	64.3	69%
G	21W	1366lm	65.0	69%
H	27W	1721lm	63.7	69%
I	11W	646lm	58.7	69%
J	21W	1366lm	65.0	69%
K	26W	1651lm	63.5	69%
L	17W	1076lm	63.3	69%
M	38W	2512lm	66.1	69%
N	25W	1651lm	66.0	69%
O	27W	1871lm	69.3	69%
P	27W	1796lm	66.5	69%
Q	31W	2086lm	67.3	69%
R	30W	2011lm	67.0	69%
S	23W	1511lm	65.7	69%
T	17W	1076lm	63.3	69%
U	24W	1581lm	65.9	69%
V	25W	1651lm	66.0	69%
W	38W	2512lm	66.1	69%
X	27W	1721lm	63.7	69%
Y	21W	1366lm	65.0	69%
Z	27W	1796lm	66.5	69%
Æ*	42W	2727lm	64.9	69%
Ø*	36W	2517lm	69.9	69%
Â*	25W	1656lm	66.2	69%

*On special request only.

OVERALL DIMENSIONS

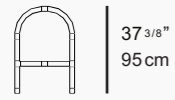

37 3/8"
95 cm

25 9/16"

65 cm



37 3/8"
95 cm

25 9/16"

65 cm



37 3/8"
95 cm

25 9/16"

65 cm



37 3/8"
95 cm

25 9/16"

65 cm



37 3/8"
95 cm

25 9/16"

65 cm



37 3/8"
95 cm

25 9/16"

65 cm



37 3/8"
95 cm

25 9/16"

65 cm

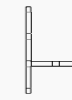

37 3/8"
95 cm

25 9/16"

65 cm

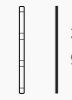

37 3/8"
95 cm

2"

5 cm



37 3/8"
95 cm

25 9/16"

65 cm

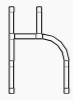

37 3/8"
95 cm

25 9/16"

65 cm



37 3/8"
95 cm

25 9/16"

65 cm

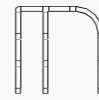

37 3/8"
95 cm

37 3/8"

95 cm



37 3/8"
95 cm

25 9/16"

65 cm



37 3/8"
95 cm

25 9/16"

65 cm

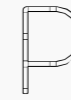

37 3/8"
95 cm

25 9/16"

65 cm



37 3/8"
95 cm

25 9/16"

65 cm

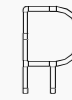

37 3/8"
95 cm

25 9/16"

65 cm



37 3/8"
95 cm

25 9/16"

65 cm



37 3/8"
95 cm

25 9/16"

65 cm



37 3/8"
95 cm

25 9/16"

65 cm



37 3/8"
95 cm

25 9/16"

65 cm



37 3/8"
95 cm

37 3/8"

95 cm



36"
91.5 cm

36"

91.5 cm



37 3/8"
95 cm

25 9/16"

65 cm



37 3/8"
95 cm

25 9/16"

65 cm

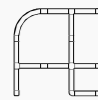

37 3/8"
95 cm

37 3/8"

95 cm



Ø 1 3/4"
Ø 4.5 cm

3 9/16"

9 cm



37 3/8"
95 cm

25 9/16"

65 cm



Ø 1 3/4"
Ø 4.5 cm

3 9/16"

9 cm



45 11/16"
116 cm

25 9/16"

65 cm



Ø 1 3/4"
Ø 4.5 cm

3 9/16"

9 cm

AOL Lowercase Wall

PERFORMANCE

LIGHT SOURCE	LED
LIGHT DISTRIBUTION	Direct / Indirect
COLOR RENDERING INDEX	80CRI
COLOR TEMPERATURE	3000K 

FEATURES

FUNCTION	Indoor signage lighting
BODY FINISH	Opal diffusing PMMA
JOINT MODULES FINISH	Opal diffusing PMMA
MOUNTING	Positioning template included
VOLTAGE	24VDC

CERTIFICATIONS



PHOTOMETRIC DISTRIBUTION

For most updated photometric data files, please visit the product page at www.artemide.net

ALPHABET CONFIGURATOR

Contact our sales agents for more information about our configuration software.

	POWER CONSUMPTION (W)	DELIVERED LUMENS (lm)	EFFICACY (lm/W)	EFFICIENCY (%)
a	20W	1296lm	64.8	69%
b	23W	1511lm	65.7	69%
c	17W	1081lm	63.6	69%
d	23W	1511lm	65.7	69%
e	20W	1296lm	64.8	69%
f	16W	1006lm	62.9	69%
g	25W	1656lm	66.2	69%
h	23W	1436lm	62.4	69%
i	8W	430lm	53.7	69%
j	13W	791lm	60.8	69%
k	23W	1436lm	62.4	69%
l	11W	646lm	58.7	69%
m	29W	1866lm	64.3	69%
n	19W	1221lm	64.3	69%
o	21W	1441lm	68.6	69%
p	23W	1511lm	65.7	69%
q	23W	1511lm	65.7	69%
r	14W	791lm	56.5	69%
s	21W	1366lm	65.0	69%
t	17W	1006lm	59.2	69%
u	19W	1221lm	64.3	69%
v	18W	1151lm	63.9	69%
w	24W	1581lm	65.9	69%
x	15W	861lm	57.4	69%
y	25W	1581lm	63.2	69%
z	24W	1581lm	65.9	69%
æ *	32W	2016lm	63.0	69%
ø *	27W	1871lm	69.3	69%
â *	25W	1656lm	66.2	69%

*On special request only.

OVERALL DIMENSIONS

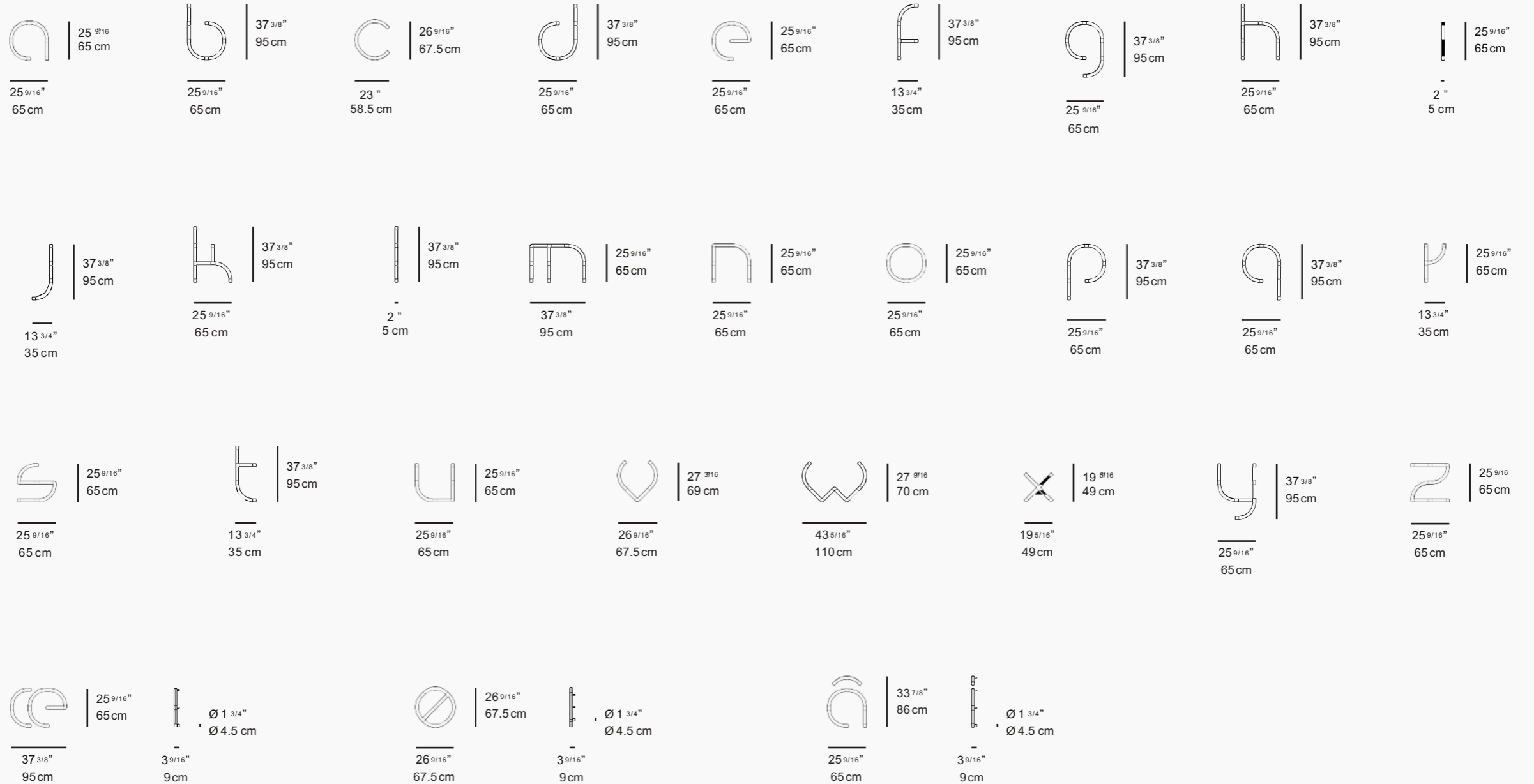

AOL NUMBER Wall

PERFORMANCE

LIGHT SOURCE	LED
LIGHT DISTRIBUTION	Direct / Indirect
COLOR RENDERING INDEX	80CRI
COLOR TEMPERATURE	3000K 

FEATURES

FUNCTION	Indoor signage lighting
BODY FINISH	Opal diffusing PMMA
JOINT MODULES FINISH	Opal diffusing PMMA
MOUNTING	Positioning template included
VOLTAGE	24VDC

CERTIFICATIONS



PHOTOMETRIC DISTRIBUTION

For most updated photometric data files, please visit the product page at www.artemide.net

ALPHABET CONFIGURATOR

Contact our sales agents for more information about our configuration software.

	POWER CONSUMPTION (W)	DELIVERED LUMENS (lm)	EFFICACY (lm/W)	EFFICIENCY (%)
0	27W	1871lm	69.3	69%
1	23W	1436lm	62.4	69%
2	28W	1871lm	66.8	69%
3	24W	1511lm	62.9	69%
4	23W	1436lm	62.4	69%
5	29W	1941lm	66.9	69%
6	25W	1656lm	66.2	69%
7	19W	1221lm	64.3	69%
8	33W	2301lm	69.7	69%
9	25W	1656lm	66.2	69%

OVERALL DIMENSIONS

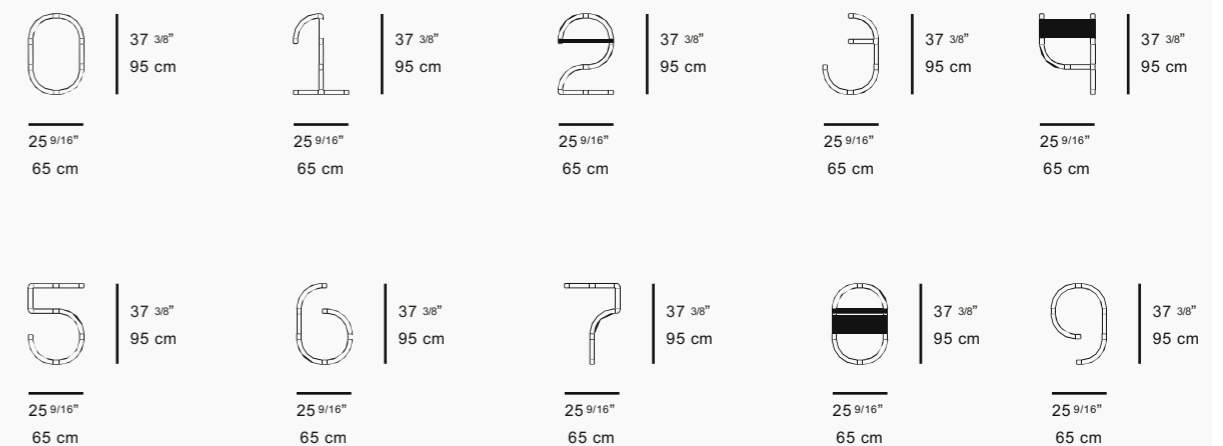



MULTINATIONAL CORPORATION OFFICES, MILAN, ITALY



MULTINATIONAL CORPORATION OFFICES, MILAN, ITALY

Artemide



what do you see?

CONSERVED

EXIT



THE UNIVERSITY OF MILAN, MILAN, ITALY
Project: Quick brown fox jumps over the lazy dog

UNITED STATES HEADQUARTERS

Artemide Inc.

250 Karin Lane

Hicksville, NY 11801

T. 631-694-9292

Toll Free 1-877-Art-9111

email: infousa@artemide.net

CANADIAN HEAD OFFICE

Artemide Canada Ltd. 11105,

rue Renaude Lapointe

Montréal, QC H1J 2T4

T. 514-323-6537

Toll Free 1-888-777-2783

email: infocanada@artemide.net

For retail sales contact information, please visit

www.artemide.net/store-locator

For contract sales contact information, please visit

www.artemide.net/sales-representative